



©Heyko Stöber

Advancements in Next-Generation Battery Technologies

Foreword by Ms. Anandi Iyer, Director, Fraunhofer Office India
Page no. 2

Battery Evolution vs. Revolution?
Interview with Dr. Kai-Christian Möller
Page no. 3

Building India's Battery Ecosystem
Interview with Dr. K. N. Satyanarayana
Page no. 5

Battery Technologies
Page no. 7

Battery Cell Innovation & Production of Prototypes
Page no. 40

Battery Centres
Page no. 54

Recent Activities, Events Calendar, and Media Coverage
Page no. 65

CONTENT

Lithium-Ion Batteries	9
The Next Generation of Battery Storage Systems	13
Manufacturing Technology for Energy Storage Systems	17
Sodium-Ion and Sodium Metal Batteries	20
Sodium Battery Materials and Prototype Manufacturing	22
Development of Sodium-Ion Batteries Using Additive Manufacturing	24
Sodium-Ion Technology: The Future of Energy Storage	25
Solid-State Batteries: Next-Generation, High-Energy Storage Systems	29
All-Solid-State Batteries	32
Battery Laboratory for the Development of Solid-State Batteries	34
Innovations for the Battery of the Future	37
Battery Cell Innovation & Production of Prototypes	41
Battery Cell Production	42
Battery Manufacturing	44
DRYtraec Technology	45
Thin Film Technology for Energy Storage Media	47
Battery Materials and Components	50
Sustainable Factory Systems	52
Battery Technology	53
Center for Electrical Energy Storage	55
The "FFB PreFab" - Battery Production Research All Along the Line	57
Fraunhofer Center for Energy Storage and Systems (ZEES)	59
Advanced Battery Technology Center (ABTC)	61
GreenBatt – Competence Cluster Recycling & Green Battery	62
Battery Innovation and Technology Center (BITC)	63
FAB-SH: Research Center for Applied Battery Technology	64

FOREWORD

Dear Readers,

As the global transition towards clean energy accelerates, battery technologies have emerged as one of the most strategic enablers of sustainable mobility, renewable energy integration, and industrial competitiveness. The race to develop safer, more efficient, and cost-effective energy storage solutions is reshaping global value chains and creating new opportunities for international collaboration.

In this context, the partnership between India and Germany assumes particular significance. Germany's strengths in advanced research, engineering excellence, manufacturing technologies, and industrial innovation complement India's rapidly growing market, talent pool, expanding manufacturing base, and ambitious clean energy goals. Together, both countries are uniquely positioned to drive innovation across the battery value chain—from materials research and cell design to manufacturing processes, recycling, and circular economy solutions.

The growing momentum in Indo-German cooperation is reflected in a range of joint initiatives involving industry, research institutions, startups, and policymakers. Collaborative efforts are helping bridge the gap between laboratory breakthroughs and industrial deployment while fostering resilient and sustainable supply chains.

Fraunhofer's battery research ecosystem spans the entire value chain, encompassing advanced materials, cell development, manufacturing technologies, battery testing and validation, digitalization of production processes, second-life applications, and recycling. Through dedicated facilities such as Fraunhofer Battery Alliance Network, and the expertise of multiple Fraunhofer institutes, we are supporting industry in scaling up battery production while advancing sustainable and resource-efficient technologies. Our work focuses not only on technological innovation but also on accelerating industrial adoption through pilot production, applied research, and collaborative innovation platforms.

In India, Fraunhofer has been actively engaging with industry leaders, research organizations, startups, and government stakeholders to support the country's ambitions in electric mobility and energy storage. Through technology transfer, industry consultations, technical workshops, delegation visits, and collaborative projects, we are facilitating knowledge exchange and fostering partnerships in areas such as battery manufacturing, quality assurance, testing infrastructure, recycling, and workforce development. These efforts reflect our commitment to strengthening the Indo-German innovation ecosystem and contributing to the development of a resilient and globally competitive battery value chain.

This edition of our newsletter puts the spotlight on our competencies, latest developments, success stories, and emerging opportunities in battery technologies and Indo-German collaboration. As both nations deepen their engagement in the fields of advanced manufacturing, energy transition, and innovation, batteries will undoubtedly remain a cornerstone of a future-oriented partnership. Our next edition will focus on application-oriented battery technologies for mobility and stationary energy storage, simulation tools, circular economy solutions for battery recycling, and training and skill development.

We hope this issue provides valuable insights and inspires further dialogue and collaboration among stakeholders committed to shaping the next generation of energy storage technologies. We look forward to hearing from you!

Happy Reading!



Ms Anandi Iyer
Director, Fraunhofer Office India

Battery Evolution vs. Revolution?

Interview with Dr. Kai-Christian Möller

Dr. Kai-Christian Möller,
Deputy Spokesperson,
Fraunhofer Battery Alliance



DR. KAI-CHRISTIAN MÖLLER

Dr. Kai-Christian Möller received his doctorate in electrochemistry from the University of Münster in 1998. After several years of research on lithium batteries at Graz University of Technology, he joined the Fraunhofer Institute for Silicate Research ISC in 2006, where he established the “Center for Applied Electrochemistry.” In 2012, he became Deputy Spokesperson of the Fraunhofer Battery Alliance and Head of the “Electrochemical Storage” project group at the Fraunhofer Institute for Chemical Technology. In 2015, this group merged with the corresponding group at Fraunhofer ISC. Since 2015, Kai-Christian Möller has been responsible for inter-institutional projects in battery and fuel cell research within the “Corporate Business Development” department at Fraunhofer headquarters in Munich.

Dr. Kai-Christian Möller, Deputy Spokesperson for the Fraunhofer Battery Alliance, calls for greater continuity in the funding, research, development, and production of batteries in Germany in the following interview. E-mobility must become attractive again. Germany can keep pace, but stagnation and uncertainty will set us back years.

Dr. Möller, as a PhD electrochemist, you are someone who should know the key to battery technology, both today and tomorrow. When you think about cell research and development, where would you place our current situation in Germany? Have we missed the boat?

To be clear: we have not missed it yet. However, the pace at which the leading international players are moving is accelerating, and we must be extremely careful to keep up. In Germany, we have already succeeded in bringing the topic into focus, although unfortunately not with the necessary consistency. The approach of developing battery chemistry and proprietary vehicle architectures for battery electric vehicles (BEVs) was absolutely right. Think of the cell research in Kamenz near Dresden. Novel cells and battery packs for the Smart were developed and produced there. However, it was still too early, and the work was discontinued. Now, for example, BMW, Mercedes-Benz, and VW have established initial pilot production lines. We are still actively working on this in Germany. However, this work must continue with consistency and with the utmost attention from policymakers.

How do you assess the importance and opportunities of battery recycling? Is the hype surrounding this topic merely a trend that many want to exploit for their own benefit?

Raw material cycles in Europe are a top priority. This ultimately leads to greater independence from global players and helps make the volatile raw material markets more manageable for the automotive industry. Batteries from the first generations of electric vehicles are now being recycled. If we assume that a battery will remain in use for around eight years and then potentially enter a second-life application, we can truly establish battery recycling — a completely new economic sector — within the next eight to ten years, one that could also gain international significance. However, we must start now by studying the processes, gathering experience, and training personnel. Then we will be prepared. Policymakers also need to become involved and create the necessary framework conditions in Germany.

So all is not lost yet?

Yes, that is exactly what I am saying. We can still succeed. It takes time, money, know-how, and, of course, people who are committed to this work every single day. The first professorships dedicated to this field have existed for only around 15 years. However, we are capable of building excellent cars. Unfortunately, we still cannot produce affordable energy — which is a real shame. The new federal government should place this issue at the very top of its agenda.

Our OEMs recognized this very early on and entered the Chinese market through joint ventures. Without this foresight, some of our flagship companies would likely no longer be in business today. Do you believe it is the right approach for us to once again seek joint venture partners and jointly bring battery development and production back to Germany?

I actually believe this is the fastest and most effective way forward. I am thinking, for example, of CATL. This could represent a breakthrough, and if we want to regain a leading position, we need strong partners at our side. Together, we are stronger in this area as well. In this way, we could build upon existing research findings and apply them for the benefit of Germany’s automotive industry. Attempting to do everything independently will be complicated. The entire world is working on this. We absolutely must remain involved.

This raises a delicate question for us. Do we in Germany perhaps already have something up our sleeve in terms of battery chemistry or battery technology that could promise us a competitive advantage — something like the philosopher's stone?

That would be fantastic, but no, we do not currently possess a unique selling point on the international market. I do not really see a single game-changing breakthrough at the moment. Lithium-ion batteries will remain with us for many years to come. This technology has advanced significantly, and the associated production technologies are also highly developed. Nevertheless, I still see considerable potential in this type of battery. The disadvantages related to materials and safety must be reduced further. To what extent and at what point other battery types, such as sodium-ion or solid-state batteries, will prevail remains an open question. Research in this area is underway worldwide. However, even in these cases, the obvious advantages regarding cost, energy density, and safety are offset by challenges such as material availability and long-term durability. It is an open race, and I see the German research landscape, overall, as being on the right track.

Dr. Möller, you have been a certified chemist for more than 30 years, gained your first valuable experience in the laboratory development of lithium-ion batteries as early as 1992, earned your doctorate in electrochemistry in Münster, and, through research and professional positions in Graz and Würzburg, eventually joined the Fraunhofer headquarters in Munich. Battery chemists are in high demand and highly sought after. If we ask you about the essential steps for German battery development and production, what immediately comes to mind?

1. We must maintain continuity. Ill-considered termination of funding programs or constant shifts in thematic priorities set us back years, if not decades. We do not need that. The approaches are fundamentally sound, and we can build upon them. However, we cannot achieve this alone. We need reliable political and financial framework conditions for broad yet application-oriented research across the entire value chain.
2. We also need a thriving e-mobility market. We can all observe the consequences of the German government's abrupt withdrawal of subsidies. Customer uncertainty is hindering the transformation, despite the enormous potential it holds. The result is stagnant markets, stalled development, and ultimately the loss of valuable competitive advantages. Look at Norway: continuous support for e-mobility has resulted in more than 95% of vehicle purchase decisions being for electric vehicles. We cannot even dream of that yet.
3. To put it very clearly: do not apply the brakes — accelerate fully, or better yet, fast-charge instead of moving in slow motion.

For further research and the creation of sustainable connections between companies, research institutions, and development partners, we rely on the Fraunhofer Battery Alliance and their expertise.

Building India's Battery Ecosystem

Interview with Dr. K. N. Satyanarayana

Dr. K. N. Satyanarayana,
Founding Director - IIT Tirupati, Andhra Pradesh



DR. K. N. SATYANARAYANA

Dr. K. N. Satyanarayana is the Founding Director of IIT Tirupati, Andhra Pradesh, and is currently serving his second term as Director. He is on deputation from IIT Madras, where he has been a Professor in the Building Technology & Construction Management Division of the Department of Civil Engineering.

He received his B.Tech. degree in Civil Engineering from IIT Madras. He subsequently received MS and PhD degrees with specialization in Construction Engineering and Management from Clemson University, USA. He has been a faculty member at IIT Madras since 1991. In 2009, he was a Visiting Professor at Iowa State University, USA.

His teaching, research, and consulting interests are in the areas of project management, construction contracts, construction productivity, construction equipment, C&D waste management, and public-private partnerships. He has published extensively in these areas. He is the recipient of many awards, including the Project Management Institute (India) Distinguished Scholar Award (2011).

He is a member of the Empowered Committee for Industrial and International Collaborations set up by the Ministry of Education, Government of India. He serves as Vice-Chairman of the Board of Advisors of The Glass Academy and as an Expert Member on the Board of Management of the Building Materials & Technology Promotion Council (BMTPC). He was a founding member of the Institute for Lean Construction Excellence. He serves on the governing boards of academic institutions such as IISER Tirupati, NIT Tadepalligudem, IIITDM Kurnool, IIIT Sri City, AIIMS Mangalagiri, NID Vijayawada, IUCAA Pune, and RGKUT. He also serves as an Independent Director on five company boards.

How is India's battery value chain maturing, and where are the most critical "missing links" between raw material sourcing and end-of-life recycling? Which battery chemistries and innovations are most promising for India?

India's battery value chain is still at an early stage of development. While the government's ACC Production Linked Incentive (PLI) scheme for 50 GWh of domestic manufacturing capacity has attracted significant investments, the ecosystem remains heavily dependent on imports. Critical materials such as lithium, cobalt, nickel compounds, graphite anodes, and cathode active materials are largely sourced from abroad. Cell manufacturing, battery management systems (BMS), recycling, and testing infrastructure are developing but require further scaling, particularly to support startups and accelerate commercialization of new technologies.

India's climate makes LFP and sodium-ion (Na-ion) batteries particularly attractive, with Na-ion offering an alternative to lithium through the use of abundant domestic resources, especially for stationary storage. In parallel, research institutions and startups are advancing next-generation technologies such as solid-state and zinc-based flow batteries for cost-effective, large-scale grid storage applications.

What are the key demand drivers for battery storage from a fundamental research standpoint – mobility, grid storage, or industrial applications?

At present, a major demand driver for batteries in India is electric vehicles (EVs), including significant growth in two- and three-wheeler electrification. Grid storage and Battery Energy Storage Systems (BESS) are emerging markets and are expected to become critical demand drivers in the coming years, particularly given India's target of achieving approximately 500 GW of renewable energy capacity by 2030. Industrial applications, such as replacing conventional lead-acid batteries in telecom tower backup systems and applications in mining equipment, material handling, and defence, are only beginning to be explored.

Key challenges in the EV segment include fast charging, energy density, thermal management, cycle life, recyclability, and reuse. Fundamental research questions that need to be addressed include solid-electrolyte interphase stability, lithium plating (especially during fast charging), and dendrite suppression. For grid storage applications, challenges include safety at scale, cost per kWh, and electrolyte degradation over long operating cycles. For industrial applications, robustness under harsh environmental conditions and operation across a wide temperature range are critical requirements. Of the three segments, I believe India must prioritize research on grid storage in order to meet its renewable energy targets and achieve decarbonization at scale.

What are the major challenges in translating advanced battery research into scalable, commercially viable solutions, and how can collaboration between industry, academia, and applied R&D institutions help bridge this gap?

Most battery research in India stops at TRL 3–4 (laboratory proof-of-concept), focusing on material development at the gram scale. There are limited pilot-scale facilities, such as electrode coating lines, dry rooms, and formation cycling equipment, available to advance these technologies to TRL 6–7. For example, a cathode material that performs well at a 1 g scale may behave very differently at a 1 kg or 1 tonne scale due to synthesis kinetics, impurity profiles, and particle-size distribution. Researchers and companies also have limited access to advanced testing and characterization infrastructure. Facilities for cryo-TEM, synchrotron XRD, and operando electrochemical characterization are limited and unevenly distributed across the country. There are virtually no domestic vendors manufacturing equipment for battery cell fabrication, even at pilot scale. This makes Indian battery manufacturers heavily dependent on foreign vendors for both equipment and knowledge transfer. Consequently, many companies prefer to license proven foreign technologies due to the risks involved and the limited domestic know-how related to large-scale production.

To overcome these challenges, initiatives such as the NITI Aayog-backed National Mission on Transformative Mobility and Battery Storage and MeitY's Electronics & E-Waste Battery Programs are promoting co-funded, milestone-driven research with clear

IP-sharing frameworks. Efforts are also underway to establish government-funded, industry-accessible pilot lines for electrode manufacturing and cell assembly, similar to the Fraunhofer model in Germany and the NREL model in the United States, particularly to support startups developing new chemistries. In addition, academic and R&D institutions such as the IITs, IISERs, CECRI, ARCI, and CSIR laboratories are actively working on scaling synthesis processes and building prototype cells to advance technological know-how in these areas.

What are the gaps related to battery safety, testing, and standardization? (What are the key gaps in standards and testing infrastructure in India?)

India follows a combination of BIS (Bureau of Indian Standards), AIS (Automotive Industry Standards), and IEC/UN international standards. However, greater harmonization among these standards is still required. For grid-scale BESS applications, both storage and safety standards need to be updated to account for tropical climate conditions. India also lacks localized standards for grading, certifying, and deploying retired EV batteries in stationary storage applications.

Most facilities in India can currently perform cell-level characterization, including electrical, thermal, mechanical, and electrochemical testing, for cells up to 50 Ah. However, testing infrastructure for higher-capacity cells is limited. Environmental simulation capabilities that combine factors such as dust, humidity, and vibration are also largely unavailable, despite being critical for Indian operating conditions. Only a handful of NABL-accredited laboratories, such as ARAI and ICAT, are capable of conducting comprehensive battery pack-level testing. In addition, a certification framework for BMS software is critical from a safety perspective and requires further development. To address these challenges, dedicated national battery testing and certification centres equipped with tropical climate simulation chambers, abuse-testing rigs, and pack-level electrochemical characterization facilities should be established across the country.

How are the ANRF and other allied programmes of the Government of India supporting the development of indigenous technology capability in India?

The Anusandhan National Research Foundation (ANRF), established under the ANRF Act 2023, is India's apex R&D funding body with a proposed outlay of ₹500 billion over five years. It is expected to support mission-mode programs in clean energy storage and accelerate the translation of research into industry-ready technologies through competitive, outcome-linked grants. Complementing this, the Ministry of Heavy Industries' ₹181 billion Advanced Chemistry Cell (ACC) program aims to build giga-scale domestic battery manufacturing capacity, while NITI Aayog's National Mission on Transformative Mobility provides the policy framework for EVs and energy storage through manufacturing incentives, market development, and coordinated policy implementation. Additionally, MeitY supports battery innovation through R&D, battery management systems, recycling, electronics manufacturing, and startup incubation, while MNRE, through SECI, is driving grid-scale Battery Energy Storage System (BESS) deployment using Viability Gap Funding (VGF).

To maximize the impact of these initiatives, stronger coordination across ministries through a single nodal agency could improve execution and accelerate ecosystem development. Expanding shared pilot-scale cell manufacturing facilities is also essential to support indigenous battery production and reduce the gap between laboratory research and commercialization. Equally important is developing a skilled workforce in electrochemistry, materials science, and battery manufacturing. Specialized programs such as IIT Tirupati's Master's in Advanced Energy Storage should be replicated across more universities to meet the growing demand for talent as India scales up its domestic battery manufacturing capabilities.



BATTERY TECHNOLOGIES

Li-ion X, Na-ion, Solid-State, ...



©Fraunhofer ISE

LITHIUM-ION BATTERIES (LIB)

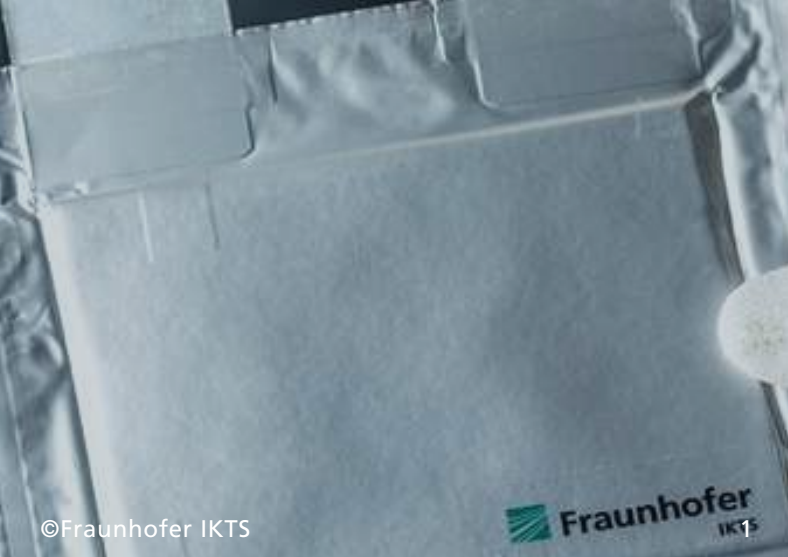

©Fraunhofer IKTS

Fraunhofer IKTS



©Fraunhofer IKTS

2

Lithium-Ion Batteries

FRAUNHOFER IKTS IN PROFILE

The Fraunhofer Institute for Ceramic Technologies and Systems IKTS conducts applied research on high-performance ceramics. The institute's three sites in Dresden (Saxony) and Hermsdorf (Thuringia) represent Europe's largest R&D institution dedicated to ceramics.

As a research and technology service provider, Fraunhofer IKTS develops modern ceramic high-performance materials, customized industrial manufacturing processes, and prototype components and systems across complete production lines, from laboratory to pilot-plant scale. Furthermore, the institute possesses expertise in the diagnostics and testing of materials and processes. Test procedures in the fields of acoustics, electromagnetics, optics, microscopy, and laser technology contribute substantially to the quality assurance of products and plants.

The institute operates across eight market-oriented business divisions to demonstrate and qualify ceramic technologies and components, as well as non-destructive testing methods, for new industries, product concepts, and markets beyond established fields of application. Industries addressed include ceramic materials and processes, mechanical and automotive engineering, electronics and microsystems, energy, environmental and process engineering, bio- and medical technology, optics, as well as materials and process analysis.

Ceramic materials and technologies are essential components of today's lithium-ion batteries and will continue to play a key role in the future. At Fraunhofer IKTS, development work is carried out at the pilot scale to ensure the rapid transfer of results from fundamental laboratory research to industrial process development.

Fraunhofer IKTS applies its ceramics expertise to the synthesis and preparation of active materials and separator components, as well as to their processing into battery electrodes. A variety of methods is available for the characterization of electrode structure, electrochemical behavior, and aging during battery operation. As a result, a comprehensive understanding of the relationship between production conditions and battery reliability has been achieved.

Decades of expertise in the development of ceramic materials and technologies, as well as in materials analysis and electrochemical characterization, ensure that new cost-effective strategies can be established. This includes materials, process, and systems development, as well as the provision of groundbreaking cell concepts for mobile and stationary applications.

In addition to the aforementioned materials and technology competencies, Fraunhofer IKTS possesses extensive expertise in the field of materials recovery and the circular economy. Through the development of efficient recycling concepts for lithium-ion batteries, it contributes to ensuring that energy storage systems are not only technically and economically viable, but also environmentally friendly and sustainably produced.

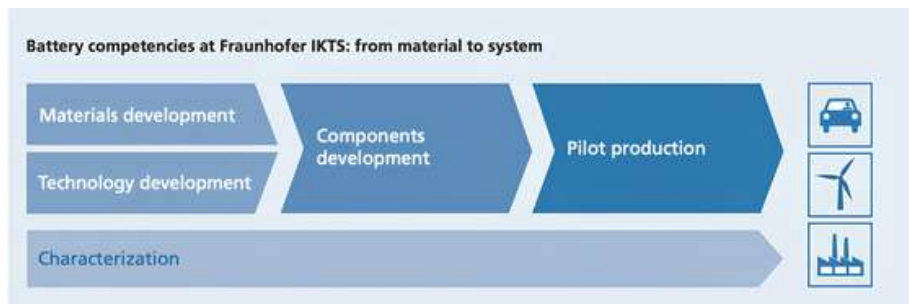

MATERIALS DEVELOPMENT

Powder Synthesis and Preparation

The development of competitive lithium-ion batteries begins with the synthesis and preparation of tailored powders (active materials, ceramic electrolyte materials, and separator materials). As cathode costs account for around one-third of the overall cell material costs in the current generation of lithium-ion batteries, demand-specific and scalable synthesis routes are essential for reducing costs. In addition, production methods are key to achieving further increases in specific storage capacity, cell voltage, power density, and service life. This, in turn, requires precise control of particle size and morphology.

At Fraunhofer IKTS, two process routes are employed. In the top-down approach, commercial powders are reduced to the desired size using mechanical preparation processes and are subsequently classified. In the bottom-up approach, particle size, distribution, and morphology are adjusted to the appropriate levels during the synthesis of the primary particles (0.1–50 µm).

1. IKTS test cell and electrode coils.
2. Electrode coils.



©Fraunhofer IKTS

1

© Fraunhofer IKTS

2

In addition to classic solid-state reactions and spray-drying-based methods utilizing precursor compounds, sol-gel methods under normal pressure, as well as hydrothermal and solvothermal syntheses using microwave-assisted reactors, are employed. High purities and inert process conditions are required for the resultant primary particles to be processed into homogeneous powders with well-defined functionalities. For the production of active mixtures, powders with precisely defined granule morphologies, sizes, and compositions, as dictated by the respective applications, are required, for example, for high-power and high-energy electrodes or solid-electrolyte cell concepts.

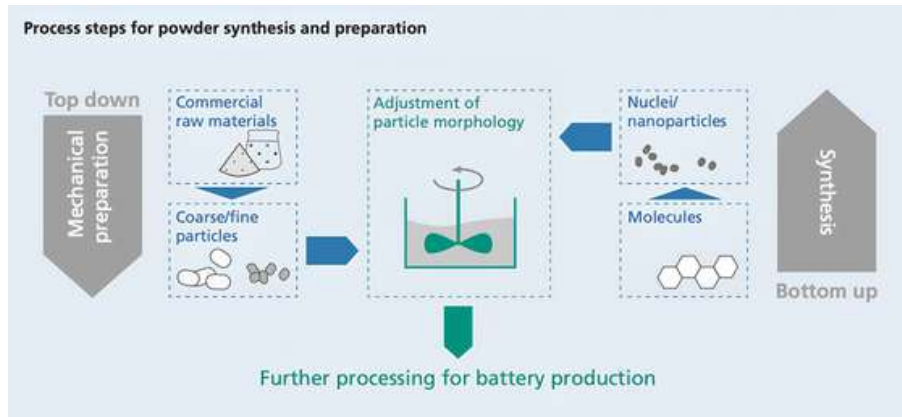

Fraunhofer IKTS offers all processes required for the modification, tailoring, and characterization of the properties of battery powders (5–100 µm) and their chemical precursors. With the equipment and expertise available at Fraunhofer IKTS, quantities ranging from small batches of up to one kilogram to pilot-scale quantities of several hundred kilograms can be handled.

Accompanying Analytics

Microscopic material behavior, aging, and degradation, as well as the influence of production technologies, exhibit mutual dependencies throughout the entire battery development and production process. Therefore, measurement-assisted evaluation of powder-based battery components during the course of the process provides valuable information for targeted process analysis, monitoring, and optimization.

At Fraunhofer IKTS, state-of-the-art equipment and a comprehensive portfolio of highly advanced analytical methods are available. In addition to standard analytical methods such as FESEM, TEM, XRD, EDX, Raman spectroscopy, and IR spectroscopy, a number of specialized techniques can also be employed. In recent years, Fraunhofer IKTS has established ion beam-based preparation methods (FIB/BIB) that enable delicate samples, such as granules, electrodes, or pre-sintered components, to be prepared in a manner that allows the internal structures and microstructure to be imaged at high resolution and without artifacts. This makes it possible to visualize the distribution of solid materials and organic components, such as binders, across the sample cross section. Based on this information, process technologies can be optimized and degradation mechanisms can be investigated.

Fraunhofer IKTS also enables the direct transfer of samples in a protective gas atmosphere from the glove box to a scanning electron microscope or an X-ray diffractometer for subsequent analysis. This prevents reactions of the materials with air and the resulting changes in material properties.

1. Tailored cathode powders produced at Fraunhofer IKTS.
2. Analysis of the battery materials at the scanning electron microscope.



©Fraunhofer IKTS

1

© Fraunhofer IKTS

2

TECHNOLOGY DEVELOPMENT

Slurry Preparation

In the conversion of the starting powders into a homogeneous slurry, all components must be adapted to the applied coating process and the desired electrode properties. In this regard, Fraunhofer IKTS draws on its expertise in ceramic technologies. The active materials define the capacity, while the conductive additives are decisive for the electrode resistance. In addition, the organic binder materials used largely determine the subsequent mechanical stability of the electrodes, their processability, and their cycling stability.

Fraunhofer IKTS utilizes various mixing units, such as dissolvers, planetary mixers, and kneaders, for tailored slurry preparation. During processing, parameters such as energy input, temperature control, particle stability, atmosphere, and mixing duration determine the degree of dispersion. At the end of the mixing process, coordinated process routes ensure a homogeneous particle distribution within the slurry and prevent re-agglomeration.

Fraunhofer IKTS focuses on replacing organic solvents with water-based solvents and reducing solvent content in order to maximize the environmental friendliness of the production process.

Electrode Production

Doctor blade, comma bar, and slot-die coating processes, as well as various drying methods, are used in the development of electrode coating technologies. Batch processes such as screen printing and mask extrusion enable flexible design of electrode geometries.

The selection of suitable process parameters during electrode manufacturing can significantly improve long-term stability and performance, while also offering advantages in terms of cost-effectiveness, quality, and production speed. The focus is placed on the following:

- Optimum adhesion and binder distribution after drying
- High coating speeds
- Surface quality (no blowholes or particles)
- Prevention of gas pockets
- Minimal fluctuations in layer thickness

Significant cost-saving potential can be realized through the optimization of temperature profiles in the drying zones and monitoring of the electrode drying process. However, these energy savings must not adversely affect adhesion, morphological properties, electrode quality, or process speeds. The final electrode porosity is defined through the subsequent calendaring process.

Electrolyte Filling

The process times associated with the elaborate filling procedures used for lithium-ion battery cells, as well as the long durations required for penetration of the electrolyte into the separator and electrodes, still represent a major cost factor in battery production. These are closely related to the design of the electrodes and the electrode-separator assembly. A homogeneous distribution of the electrolyte within the cell is also a prerequisite for reliable formation and long cell life.

The penetration behavior of the electrolyte within the cell is influenced by numerous factors, the most important of which are the wettability of the electrodes and separator, as well as the capillary forces within the separator membrane and at the interface between the separator and the electrodes. Based on extensive knowledge of the viscosities, surface tension, and pore structures of the electrode and separator materials, an electrochemical method was developed to determine the correlations between structure and properties in separator-electrode systems.

1. Mixing and strip coating.
2. Electrode coating.

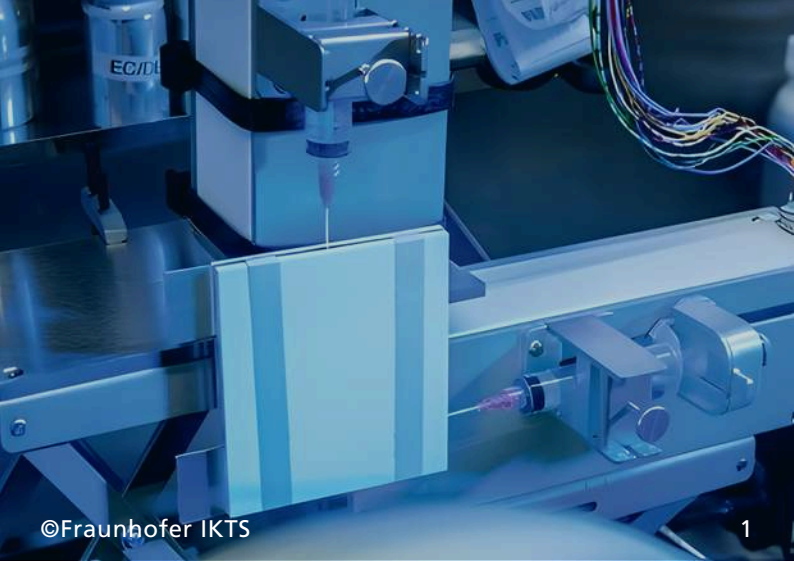

©Fraunhofer IKTS

1



© Fraunhofer IKTS

2

The method also enables monitoring of the penetration process, allowing the penetration behavior of separators, electrodes, and separator-electrode assemblies with electrolytes to be described systematically and quantitatively.

Test Cells and Cell Design

At Fraunhofer IKTS, both coin cells and laboratory-scale pouch cells are used for the preliminary characterization of developed materials and processes. The manufactured electrodes are stamped according to the final cell format, tailored, and dried to achieve minimal residual moisture levels. Subsequent cell assembly and electrolyte filling are carried out in glove boxes under an argon atmosphere.

Following functional testing and formation, the cells are subjected to various tests. In cooperation with thyssenkrupp System Engineering GmbH, pouch cells with capacities of up to 5 Ah can also be manufactured in a joint pilot-scale facility.

In addition to the assembly of test cells, conceptual design activities are undertaken to develop cell designs tailored to specific application requirements through the coordinated development of materials and processes.

Development work focuses on bipolar lithium-ion batteries, with particular emphasis on aspects such as the properties of bipolar electrodes, interactions with downstream processes, and adaptation to the electrolyte and other components.

1. Electrolyte filling investigations in lab-scale.
2. IKTS test cell from the pilot-scale battery facility.



©Fraunhofer ISE

1



©Fraunhofer ISE

2

The Next Generation of Battery Storage Systems

The energy transition and the sustainable transformation of the mobility sector can only succeed with the support of safe, reliable, and high-performance battery storage systems. The demand for corresponding technologies for electrical energy storage is therefore expected to increase exponentially. A sustainable circular economy, as addressed by the European Battery Regulation, will also be essential to achieving the defined goals. In this context, digitalization plays a central role in the areas of production, usage phase, and end-of-life (EOL). The requirements for battery management systems defined as part of the battery passport — for example, with regard to transparency concerning battery condition and remaining service life — are further accelerating this development.

At the Center for Electrical Energy Storage, Fraunhofer ISE researches the next generation of lithium-ion batteries as well as promising alternatives such as zinc-ion and sodium-ion technologies. The institute addresses the entire value chain, from materials and cells to battery system technology and a wide range of storage applications. Within its laboratory infrastructure at Freiburg's "Haidhaus," Fraunhofer ISE offers extensive scientific testing and inspection at both cell and system level, as well as state-of-the-art characterization processes.

RESEARCH TOPICS

In the Business Area of "Electrical Energy Storage," Fraunhofer ISE's work focuses on the following research topics:

Battery Materials and Cells

Within the research topic "Battery Materials and Cells," Fraunhofer ISE focuses on innovative and sustainable materials and technologies for energy storage. With a laboratory space of approximately 1,140 m², interdisciplinary teams are dedicated to the development, refinement, and innovative manufacturing processes of new materials. The institute's activities range from the investigation of various cell architectures to prototype development.

Fraunhofer ISE researches different cell chemistries with monovalent charge carriers, including lithium-ion and sodium-ion technologies, as well as multivalent charge carriers, including zinc-ion and aluminum-ion technologies. Research also includes battery technologies based on both liquid electrolytes and solid-state electrolytes in order to address diverse battery applications in a tailored manner.

The institute is strongly committed to sustainability and works intensively on the development of energy-efficient and environmentally friendly solutions. These efforts are embedded across all research activities and contribute to reducing the ecological footprint of batteries. Through close collaboration with the fields of production technology and technology assessment for batteries, Fraunhofer ISE integrates process engineering and techno-economic considerations, as well as AI-based cell simulations, into its work. This enables the translation of research results into practical applications and actively supports the advancement of future energy storage technologies.

Battery Engineering

Battery innovation does not only take place at the cell level; rather, the path to technological maturity lies in the optimal interaction of all components. Within the business field "Battery System Technology," Fraunhofer ISE focuses on optimizing battery systems along the entire value chain, from the cell to the complete system.

1. Pouch cell with 4.5Ah cell capacity produced at Fraunhofer ISE.
2. Electrolyte filling of a battery test cell during cell assembly.



©Fraunhofer ISE

1

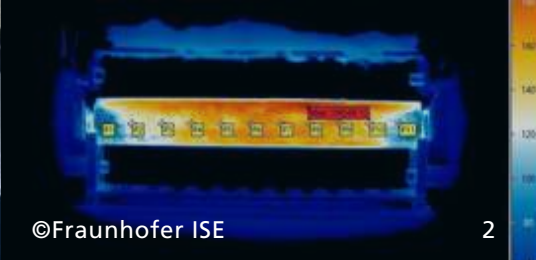

©Fraunhofer ISE

2



©Fraunhofer ISE

3



©Fraunhofer ISE

4

The institute's research and development activities cover numerous areas, including cell formation; electrical and thermal characterization of cells and modules; electrical, thermal, and aging modelling; temperature optimization; prototype construction for battery modules and systems; rapid evaluation of used (2nd life) storage systems; fast-charging methods; safety investigations; as well as the development of innovative test procedures and the required test environments.

By combining comprehensive expertise, many years of experience, innovative thinking, and a high-quality laboratory environment, Fraunhofer ISE is able to provide its customers — including manufacturers of components, battery modules and systems, system integrators, and machine and plant manufacturers — with competent support in the development of competitive products. The institute provides support at the cell level, from technology selection through the final stages of production to the development of the finished system, its components, and its integration into the intended application.

Production Technology for Batteries

Within the topic of "Production Technology for Batteries," Fraunhofer ISE focuses on procedures, processes, and technologies and their application in the manufacture of energy storage systems. The objective is to increase the safety, quality, and performance of batteries while simultaneously optimizing production technology. The institute's expertise is directed toward material, cell, and module manufacturers, plant and mechanical engineering companies, factory planners, and research institutes.

Fraunhofer ISE develops innovative processes for the production of battery materials with high purity and homogeneity and manufactures electrodes with precise microstructures in order to enhance battery performance.

Its focus lies on process development and optimization for the production of high-performance battery materials, as well as on research into manufacturing technologies for all-solid-state batteries aimed at improving energy density, safety, and service life. The institute's manufacturing technologies for pouch cells enable the production of industrially relevant cells for various energy storage applications within a production-relevant environment.

Battery Integration and Operational Management

Within the topic of "Battery Integration and Operational Management," Fraunhofer ISE focuses on the economically and ecologically optimized planning and implementation of storage-based energy systems, including the integration of one or more battery energy storage systems into an electrical supply infrastructure.

The storage systems can be installed locally or distributed across multiple locations. In the field of stationary storage systems, the institute's work covers both on-grid and off-grid applications, with a particular focus on the integration of large-scale storage systems as well as medium-sized commercial, industrial, and district storage systems. With regard to mobile applications, Fraunhofer ISE's activities also concentrate on land-based use and, in particular, on the use of storage systems in private and commercial vehicles.

The institute's expertise spans the entire value chain, from the design, simulation-based optimization, and characterization of storage-based energy systems to their demonstration and testing in the laboratory, and ultimately to field implementation. Fraunhofer ISE offers its expertise both within the framework of research projects and through individual R&D services. In this way, the institute supports battery system manufacturers, system integrators, project developers, energy supply companies, and industrial users in the successful implementation of their storage projects.

Technology Evaluation for Batteries

Within the topic of "Technology Evaluation for Batteries," Fraunhofer ISE analyzes and evaluates materials, processes, and technologies across the entire life cycle of a battery.

1. Thermal characterization of a 2nd-life cell in the isothermal calorimeter.
2. Infrared image of a test object with a thermal imaging camera.
3. Calender structure for conducting direct calendaring trials.
4. Calender system from the Fraunhofer Institute for Solar Energy Systems.



Fraunhofer ISE's R&D Services in Lithium-Ion Technologies:

- Development of Advanced Battery Active Materials
- Production and Characterization of Battery Electrodes
- Assembly and Characterization of Lithium-Ion Batteries
- Development of Next-Gen Electrolytes and Additives

Fraunhofer ISE's R&D offerings in the area of "Development of Advanced Battery Active Materials" include:

- Development of silicon-based anode active materials and their production with daily throughput at kilogram scale
- Particle refinement, including surface modification and surface coating
- Production of cathode active materials (CAMs) through solid-state synthesis, aqueous co-precipitation of precursors followed by a lithiation step, direct recycling, or hydrometallurgical recycling of end-of-life LIBs
- Characterization of particle size, morphology, pore size distribution, specific surface area, surface chemistry, and density using in-house measuring instruments
- Electrochemical characterization of active materials and benchmarking against reference materials

The objective is to identify the most sustainable and suitable technology option by considering economic, ecological, and social impacts under specific boundary conditions. The institute's expertise is directed toward industrial enterprises, companies, and research institutions.

Fraunhofer ISE is actively engaged in the development of new technologies and processes for the efficient and cost-effective industrial-scale production of battery cells. Its research includes comprehensive techno-economic and ecological assessments of technology options. Through detailed process modelling and material flow analyses, the institute evaluates both existing standard processes and innovative new approaches.

Fraunhofer ISE's direct collaboration with experts enables the institute to evaluate various processes from laboratory to pilot scale. The institute is also active in the field of battery recycling, where it develops innovative recycling processes and works on the recovery of valuable and critical raw materials.

Digitalization in Battery Research and Production

Within the research topic of "Digitalization in Battery Research and Production," Fraunhofer ISE utilizes the extensive volumes of data generated through its research activities to develop innovative digital solutions. To this end, the institute is expanding the necessary digital infrastructure, creating interfaces, and defining standards for research data management in accordance with the FAIR principles (findable, accessible, interoperable, reusable). This enables efficient processing, aggregation, and linking of data across the entire battery value chain. The institute's approaches range from material development and production to operation and second-life qualification. In this context, Fraunhofer ISE develops new tools and services for data analysis and visualization.

The institute develops customized solutions for automated documentation and data processing and applies advanced statistical methods and artificial intelligence (AI) to datasets of various sizes. In doing so, Fraunhofer ISE addresses current challenges in battery research and combines its in-depth domain expertise with capabilities in data science and software engineering.

These activities enable the institute to create new data-based offerings for industrial contract research and collaborative projects. For example, Fraunhofer ISE can identify and analyze specific correlations between individual data points across the battery value chain within its extensive databases.

Its services are aimed at companies of all sizes, with a particular focus on small and medium-sized enterprises (SMEs). The institute's target groups include battery cell, module, and system manufacturers; battery users, including second-life operators; as well as organizations in the banking and insurance sectors.

LITHIUM-ION TECHNOLOGIES

Lithium-ion batteries (LIBs) are revolutionizing the energy landscape, powering applications ranging from portable electronics to electric vehicles and renewable energy systems. With their high energy density, efficiency, and long cycle life, LIBs are essential for the transition toward sustainable energy solutions. Ongoing advancements in materials and design are making these batteries more environmentally friendly and cost-effective, addressing the growing demand for reliable energy storage.

At Fraunhofer ISE, research focuses on the entire lifecycle of lithium-ion batteries, beginning with the development of advanced battery active materials and extending to the recovery of battery materials through innovative recycling processes. The production and characterization of active materials, electrodes, and battery cells are carried out in specialized laboratories, including clean rooms and dry rooms operating under various atmospheric conditions.

1. Thermal processing of active material precursors for the production of silicon-based anodes for lithium-ion batteries in the StrOboBatt project.
2. Scanning electron microscope for analyzing particles and surface morphology as well as the composition of electrodes and their components.



Fraunhofer ISE actively supports research and development projects while collecting data for techno-economic analyses of lithium-ion technology. The institute's research improves the performance and sustainability of lithium-ion batteries, ensuring that they meet the demands of modern applications while contributing to a more sustainable future. Through these efforts, Fraunhofer ISE identifies opportunities for improvement and innovation, advancing sustainable practices and the overall efficiency of battery technologies.

Development of Advanced Battery Active Materials

Active materials are a crucial component of lithium-ion battery cells. For the anode, modern LIBs typically utilize a blend of graphite and silicon-based composites, while the cathode primarily employs lithium-nickel-manganese-cobalt oxides (NMC) and lithium-iron phosphate (LFP).

Production and Characterization of Battery Electrodes

In addition to the selection of active materials, the other electrode components — including binders, conductive additives, solvents, and additives — play a crucial role in the performance of lithium-ion batteries. Fraunhofer ISE has the capability to produce and characterize battery slurries and electrodes, ranging from a few milliliters of paste up to liter scale.

DEVELOPMENT OF BATTERY SYSTEMS

In the field of battery prototyping and production, Fraunhofer ISE develops battery systems tailored to specific applications for its customers. One of the institute's core areas of focus is the construction of prototypes designed for special thermal requirements. Lightweight battery packs are another example of the application-specific implementation of its expertise.

Prototype Development

Common challenges in the development of battery systems include cell selection, functional component selection, and volume or weight optimization. Fraunhofer ISE develops specialized applications that can be used in lightweight construction or high-current applications. The institute recommends suitable battery cells, procures or develops appropriate battery management systems, and dimensions all components according to the respective customer application in order to support the transfer of prototypes into demonstrator and production stages.

Highly Integrated Sensor Technology

The integration of sensors into battery systems enables the generation of additional value. In addition to temperature sensors, monitoring pressure distribution curves also provides important insights into the mechanical stability of battery systems during operation. These sensors can be connected either by cable or wirelessly, similar to battery management systems.

Fraunhofer ISE's R&D offerings in the area of "Production and Characterization of Battery Electrodes" include:

- Development of optimized formulations for battery slurries, ensuring optimal performance and stability
- Production of electrodes with varying thicknesses and compositions to meet specific application requirements
- Processing of slurries and manufacturing of electrodes under controlled atmospheres at various conditions (dew point -30°C dp to -55°C dp), along with the evaluation of ventilation concepts for production facilities and mini-environments to ensure optimal conditions for electrode fabrication and minimize moisture exposure
- Comprehensive characterization of electrode materials, including mechanical properties, porosity, and electrochemical performance
- Evaluation of the impact of different binders and additives on overall electrode performance

1. Spray drying of a dispersion to produce a powdered precursor for the synthesis of battery active materials.
2. Mechanical characterization of a battery electrode by applying a 180° peel test.
3. Assembly of battery cells in a glove box under argon atmosphere.
4. Prototypical structure of a battery.



©Fraunhofer IFAM

1



©Fraunhofer IFAM

2



©Fraunhofer IFAM

3



©Fraunhofer IFAM

4

Manufacturing Technology for Energy Storage Systems

DEVELOPMENT OF BATTERY SYSTEMS

The production of battery cells comprises a complex process chain extending from the powder to the finished cell. There are numerous interactions between the individual process steps. Changes to individual process steps therefore often result in changes throughout the entire process chain. This becomes increasingly significant the earlier the respective step is positioned within the chain. The use of novel materials, for example, generally requires the development of adapted components and matching cell concepts. Fraunhofer IFAM therefore consistently focuses on a comprehensive consideration of all aspects, from the powder to the cell.

Electrode Production

The performance of electrical energy storage systems is decisively influenced by the quality of the electrodes. According to the current state of the art, electrodes are manufactured using a film-casting process in which flowable masses consisting of active materials, conductive additives, and binders are applied onto electrically conductive carrier materials.

The process chain from the starting materials to the finished electrode comprises the process steps of mixing and dispersing, wet coating, subsequent drying, and, where necessary, calendering (densification). Each individual step must be adapted to the materials used and optimized according to the targets and requirements of the electrode.

New materials and battery technologies often require the development of new manufacturing methods and processes. To this end, Fraunhofer IFAM conducts research and development in the following areas:

- Mixing and coating technology, including scalability
- Recipe development and paste formulation for film casting and printing (printed batteries)
- PVD/CVD processes (physical and chemical vapor deposition), including thin-film electrodes, alloy anodes, and Li-free anode concepts
- Molding processes under inert conditions, for example by means of extrusion in laboratories for solid-state batteries
- Fabrication of three-dimensional gas diffusion electrodes with adapted wetting properties

The processing scale depends on the materials used and the specific research question.

Battery Cell Production

At Fraunhofer IFAM, the entire process chain for battery cell production is mapped, partly in automated form. This includes the following process steps:

- Punching or cutting
- Stacking
- Electrical contacting and packaging
- Electrolyte filling
- Sealing
- Forming

Each of these steps is adapted according to the requirements of the respective energy storage technology. This enables direct correlation between manufacturing parameters and the electrochemical performance of the manufactured battery and test cells, as well as the battery systems assembled from them. Battery safety is also critically dependent on the manufacturing process.

1. Cross section of a laboratory pouch cell of Fraunhofer IFAM.
2. Multilayer electrode stack.
3. Anodes/cathodes for lithium-ion batteries.
4. Printing process.



©Siegfried
Michael Wagner

1



©Siegfried
Michael Wagner

2



©Fraunhofer IFAM

3

In addition, the forming step has a significant influence on the cycle stability and lifetime of a battery and therefore represents a particular focus area in the context of battery aging research.

Fraunhofer IFAM develops various cell types ranging from 10 mAh up to 20 Ah and can therefore validate customer-specific material samples quickly and flexibly according to customer specifications.

Further information on desired electrode designs or cell layouts can be provided by Fraunhofer IFAM upon request.

BATTERY MATERIALS FOR LITHIUM-SULFUR AND SOLID-STATE BATTERIES

Active and passive materials play a decisive role in the performance of battery cells and serve key functions in the development of new cell technologies. A holistic evaluation of these materials includes chemical and structural characterization, as well as processing into electrodes and cells followed by electrochemical testing. In this way, electrochemical properties can be correlated with structural properties. Fraunhofer IWS contributes to this field through the development of new electrode materials for lithium-sulfur and solid-state batteries.

Materials Research for the Lithium-Sulfur Batteries

Since 2010, the development of lithium-sulfur (Li-S) batteries has been a research focus at Fraunhofer IWS. Porous carbon materials, proprietary electrolyte systems, and new anode concepts are used in button and pouch cells and investigated under application-relevant conditions. This approach enables the development of a comprehensive fundamental understanding, while innovations are protected within a dedicated patent portfolio. The work forms the basis for the development of ultra-light prototype cells for new application areas.

Materials Innovations for Sulfidic Solid-state Batteries

Sulfide solid electrolytes are characterized by high ionic conductivity and good processability. They form the foundation for a new generation of high-performance battery cells. At the same time, adaptation to electrode materials and the development of new concepts, particularly for the anode, are required.

In this field, Fraunhofer IWS contributes its own innovations and has, for example, demonstrated for the first time the solvent-free processing of cathode composites and the use of 100% silicon anodes in full cells.

Scalable Production of Ultra-Thin Lithium Anodes

Lithium layers only a few micrometers thick are a key component in many solid-state battery cells. Developing scalable methods for producing these metallic anodes represents a challenge that Fraunhofer IWS addresses through proprietary approaches.

A patented melt-coating process enables the deposition of thin lithium layers onto copper and nickel foils. Surface modification and the use of these layers for pre-lithiation of anode materials are subjects of ongoing research at Fraunhofer IWS.

1. Test preparation for the investigation of the charging and discharging behavior of battery materials.
2. Lithium metal anode – produced using a patented melting process.
3. Carbon and sulfur cathode materials.



©Fraunhofer IKTS

SODIUM-ION BATTERIES (SIB)



©Fraunhofer ISE

1

©Fraunhofer ISE

2

© Fraunhofer ISE

3

Sodium-Ion and Sodium Metal Batteries

SIMBA - Sodium-Ion and Sodium Metal Batteries for Efficient and Sustainable Next-Generation Energy Storage

The “SIMBA” project aims to develop a safe and low-cost all-solid-state sodium battery technology for stationary applications. Reducing the use of critical materials is at the core of “SIMBA,” which will employ sustainable battery materials, thereby reducing supply risks, restrictions, and environmental impacts currently associated with other technologies, such as lithium-ion batteries.

The unprecedented concept of “SIMBA” is based on the integration of a sodium-metal anode within a sodium-free assembly architecture, including a highly porous support on the anode side, a single-ion-conductive composite/hybrid polymer electrolyte, and an innovative cathode material.

“SIMBA” brings together a consortium of 16 partners from six EU and associated countries and has received funding of €8 million from the European Commission.

Fraunhofer ISE participates in “SIMBA” through the development of a new battery management system (BMS) for sodium-ion batteries. Integrating and evaluating state-of-charge and state-of-health algorithms will improve understanding of the cell chemistry and its aging effects. Fraunhofer ISE will characterize the new batteries, develop models, and improve the accuracy of estimating state parameters. To strengthen expertise in future BMS technology, Fraunhofer will also work on new techniques for developing a smart BMS integrated into the Internet of Things. This enables measurement data, aging conditions, and maintenance information to be transmitted directly to the user or manufacturer. Artificial-intelligence-powered algorithms can use this information to make more accurate predictions regarding battery health. Overall, service life can be extended and seamless operation ensured.

VORAN – Innovative Sodium-Ion Battery Storage for Stationary and Mobile Applications

In recent years, the manufacturing costs of batteries have been significantly reduced through the further development and scaling of processes and production technologies. For many years, the focus of R&D has therefore been on the development of new materials with strong potential for further cost reduction. On the one hand, the use of inexpensive and widely available starting materials can reduce active material costs. On the other hand, increasing energy density leads to a further reduction in manufacturing costs in the materials segment and also has a cost-reducing effect on all non-material-dependent areas of manufacturing costs. Compared to sodium-ion technology, lithium-ion technology presents risks in terms of raw material availability and the price stability of active materials.

Within the “VORAN” project, the prerequisites for large-scale production of sodium-ion batteries (NIB) for stationary and mobile applications are to be established. Large-scale production is to be implemented by Helmut Hechinger GmbH at the conclusion of the project. The basis for this is an innovative technology platform that enables a lean production environment and remains future-proof through the flexible use of new cell chemistries. Within the framework of this project, all components of the technology, as well as the production technologies for battery manufacturing, will be developed along the entire value chain, including battery recycling.

1. Battery module, front view with power connections.
2. Battery module, rear view with communication port.
3. Electrode for the VORAN project based on a highly porous electrode structure with a high layer thickness, produced using a dry coating process.



©Fraunhofer ISE

1

The inherent disadvantage of NIB technology compared to LIB technology with respect to energy density is due to the approximately 0.3 V lower potential compared to lithium. However, this can be compensated for at the battery module level through various measures being pursued within the project:

- **Shifting the active-to-passive material ratio toward active materials:** The higher mobility of sodium ions in the electrolyte compared to lithium ions is intended to be utilized for this purpose. This allows thicker electrodes to be used in the NIB system. The reduced number of current collector substrates and separators directly results in increased energy density at the cell level.
- **Use of a bipolar modular architecture:** The production of identical and balanced individual cells is made possible through the high precision of material dosing during electrode production based on a dry coating process. The increase in energy density is achieved through the elimination of interconnection components and the reduction of the material required to enclose the cells.

An existing technology platform for electrode production and modular architecture at Fraunhofer ISE serves as the basis for system development. The focus of the active materials is on hard carbon with a capacity of $> 300 \text{ mAh}\cdot\text{g}^{-1}$, as well as preferably nickel-free and manganese-rich layered oxides and, for example, iron-containing transition metal phosphates.

The project consortium within the VORAN project fully represents this value chain: KIT/HIU and Fraunhofer ISE (material and process development); acp (mechanical and plant engineering, recycling); and Hechinger (cell production). The partners within the VORAN consortium will also be responsible for establishing and operating large-scale production after the completion of the project.

1. Battery system consisting of two battery modules and a switch box.



Sodium Battery Materials and Prototype Manufacturing

One focus of battery research at Fraunhofer IKTS is on sodium-based batteries for stationary energy storage. The core element is the ceramic solid-state electrolyte made of Na-B''-aluminate. For this purpose, the group is able to cover all necessary manufacturing processes along the value chain up to pilot-plant scale, starting with material synthesis and preparation, followed by various shaping processes, thermal treatment, and final processing of the ceramic electrolytes. Particular emphasis is placed on extrusion. As part of a project funded by the Fraunhofer-Zukunftsstiftung, IKTS has developed an extrusion process that can be used to produce solid-state electrolytes made of Na-B''-aluminate, sealed on one side, for battery cells with a capacity of 100 Ah. Work is currently underway to further develop this extrusion process. One focus is the instrumentation of the extruder for realizing inline process monitoring in real time within the framework of Industry 4.0.

Based on these competencies, the group is also able to offer component development and sample production of components made from conventional ceramic materials.

Services Offered

Material, component, and technology development for ceramic solid-state electrolytes for sodium-based batteries, as well as components made from conventional ceramic materials.

- Technology- and product-specific studies and research
- Consulting on ceramic-compatible construction and component design
- Ceramic prototype manufacturing
- Raw material preparation (mixing, milling, spray-drying, kneading, granulating)
- Forming (uniaxial or isostatic pressing, extrusion, green processing)
- Thermal processing (calcination, debinding, sintering up to 1750 °C)
- Finishing (white processing)
- Laser welding of metallic components (e.g. for the integration of electrolytes into cell housings)
- Single-part and prototype production (up to small series)
- Pilot production on an industrial scale
- Upscaling of technologies
- Technology transfer to industry

A WORLD'S FIRST: LARGEST EXISTING NaNiCl₂ CELLS IN cerenergy® BATTERY MODULE

Stationary energy storage is one of the most promising growth markets in Germany, Europe, and worldwide. In connection with this trend, solutions beyond lithium-ion and lead-acid technologies are of particular interest because they provide high safety at low acquisition and operating costs. Sodium technology is poised to make a comeback in a new form, ready to address the energy storage requirements of the future.

ZEBRA Battery – An Established Technology, Re-invented

The successful development of the battery formerly known as "ZEBRA – Zero Emission Battery Research Activities" began as early as the 1980s. This type of battery operates at approximately 300 °C and essentially uses the materials sodium chloride (NaCl) and nickel (Ni). However, toward the end of the 1990s, research shifted toward emerging lithium-ion batteries, and the advancement of the ZEBRA battery was largely halted.

1. Extrusion of solid-state electrolytes made of Na-B'' aluminate for stationary batteries.
2. Assembly of a high-temperature laboratory cell with a capacity of 5 Ah.



©Fraunhofer IKTS

1



©Fraunhofer IKTS

2



©Fraunhofer IKTS

3

Nevertheless, these batteries never completely disappeared from production. The three largest batteries currently operated worldwide in the MWh range are high-temperature batteries — so-called sodium-sulfur batteries. They are based on the same technology and the same solid-state electrolyte: sodium beta-aluminate. Due to the intrinsic safety of the NaNiCl₂ battery type and the fact that the raw materials are locally available and non-strategic, development at IKTS over the past five years has focused on re-engineering this battery, with particular emphasis on manufacturing, layout, and size.

Technological Challenges Mastered

A cost-effective extrusion process was established for the production of the core element of the high-temperature battery: the solid electrolyte. In combination with a new cell layout, this has enabled upscaling. Numerous offset recipes and ceramic-metal bonding variants had to be tested and optimized during development. The seal proved to be another technological challenge, as it must demonstrate long-term stability in a sodium vapor atmosphere. As a result of the development work, 100 Ah cells have now been realized for the first time, instead of the 38 Ah cells typically available on the market. The world's largest NaNiCl₂ cell in terms of capacity has already been successfully tested in stationary battery modules.

Fraunhofer IKTS – A Partner in Battery Development

The range of services at IKTS includes the development and manufacture of ceramic electrolyte prototypes, the electrochemical measurement of high-temperature cells, post-mortem analyses, and cell and module development, including energy system simulation for customer-specific applications.

1. 100 Ah NaNiCl₂ battery cells.
2. High-temperature battery test stand.
3. cerenergy@-battery module in test stand.



©Adobe Stock/JustSuper

Development of Sodium-Ion Batteries Using Additive Manufacturing

In the project “3DPrintBatt,” Fraunhofer IFAM and partners from industry and research are transferring the 3D printing of sodium-ion batteries for electromobility and other applications to pilot production. The experts are combining battery expertise with know-how in Additive Manufacturing.

Novel Solid-State Batteries as a Promising Alternative to Lithium-Ion Batteries

“The battery of the future is safe, sustainable, flexible, and powerful. That is why we are researching new types of solid-state batteries, as these enable higher energy densities and greater safety,” says Ingo Bardenhagen, Head of “Solid State Ionics and Interfaces” at Fraunhofer IFAM. “In this context, batteries with a solid-state electrolyte based on sodium represent a promising alternative to established lithium-ion technology, since the raw material sodium is significantly more environmentally friendly, more readily available, and less expensive than lithium.”

The project focuses on the further development of the solid ion conductor and the construction and characterization of battery cells based on it. In addition to the production of thin layers to reduce the internal resistance of the battery, the operating conditions for this new battery technology must also be determined.

Special Focus on Paste Development and Production

The production of prototype sodium batteries will be designed in such a way that a wide variety of active materials can be used. As a result, product-specific adjustments to the battery can be implemented quickly and cost-effectively at the cell level. “The printing process plays a decisive role in this and, in addition to geometric adaptation, also enables volumetric optimization,” explains Jonas Deitschun, Head of “Functional Printing” at Fraunhofer IFAM.

The project primarily incorporates expertise from the areas of paste development, printing processes, and processing. Paste development and production form the basis for the subsequent batteries and therefore represent a particular focus of the project. Subsequent processing by means of screen printing is significantly influenced by the established paste properties, and the resulting cell performance is also highly dependent on the composition and internal structure of the printed electrodes.

About the Project

The project “3DPrintBatt – Sustainable, Flexible Additive Manufacturing Technology for Sodium-Ion Solid-State Batteries” was launched in March 2022 and will run until December 2027. It is funded by the German Federal Ministry for Economic Affairs and Climate Protection with a total budget of 25 million euros (funding code 16BZF351C), of which Fraunhofer IFAM contributes a budget of 5.5 million euros. Approximately 500,000 euros will be invested in a new innovation line for the production of solid-state sodium-ion cells, which will be established at the institute.

The aim of the project is to establish 3D printing processes for the production of sodium-ion batteries. In addition to developing the printing processes, particular attention is being paid to process monitoring during production.

The project will conclude with the construction of a demonstrator based on additively manufactured battery cells.

The consortium is led by ZEISS Industrial Metrology Technology. The participating partners are the Institute for Particle Technology (iPAT) at TU Braunschweig, Varta AG, Leica Microsystems, Intego GmbH, db-matik AG, HORIBA Europe GmbH, the Institute for Nanotechnology and Microscopy gGmbH, and the Fraunhofer Institutes IFAM, IST, and IKTS.

Sodium-Ion Technology: The Future of Energy Storage

Sodium-ion technology offers a promising and competitive alternative to commercial lithium-ion batteries for various applications. Sodium-ion batteries provide advantages in terms of sustainability, as well as the use of readily available and environmentally friendly raw materials. They also perform well with regard to safety and temperature resilience.

Both the functional principle and the manufacturing and process chains are almost identical to those of established lithium-ion technology. For this reason, sodium-ion batteries are referred to as a drop-in technology — a high entry-level technology readiness level (TRL) therefore enables promising future application scenarios.

With their long-standing expertise, the Fraunhofer institutes can contribute to sodium-ion development across the entire TRL spectrum, from the lowest to the highest levels. The focus lies on the development of active materials, process technologies, and component production through to cell assembly. In addition, “design for recycling” concepts and sustainability aspects are considered at all levels. Another focus is placed on drop-in capability, the adaptation of existing process technologies to industrial scale and market requirements, as well as techno-economic assessments and European technology independence.

Innovation Partner: Fraunhofer Battery Alliance

As an innovation partner, the Fraunhofer Battery Alliance offers comprehensive consulting and development services, as well as the opportunity to demonstrate various sodium-ion cell concepts. These include:

- Low-cost SIB (sodium-ion battery), with a focus on material selection and process optimization for competitive costs
- Sustainable SIB, aimed at achieving the most sustainable value chain possible, including tailored process optimization such as aqueous or solvent-free dry process steps
- High-performance SIB, targeted at the electromobility market with the objective of achieving the highest possible energy density
- Safe SIB, focused on safety concepts and experimental validation

PROJECT EXAMPLES

HyPerium Project: Sodium Solid-State Batteries with Polymer-Ceramic Solid Electrolytes for Stationary Energy Storage

The Fraunhofer Institute for Chemical Technology (ICT) is collaborating with the Jülich Research Centre (Institute for Energy and Climate Research, Materials Synthesis and Manufacturing Processes (IEK-1)), the Institute for Mechanical Process Engineering and Mechanics (MVM) at the Karlsruhe Institute of Technology (KIT), and the Helmholtz Institute Ulm (HIU) on sodium solid-state batteries with polymer-ceramic solid electrolytes. The consortium aims to develop such batteries as a cost-effective and efficient alternative to lithium-ion batteries for stationary energy storage.

The project, named “HyPerium” (Hybrid Polymer-Ceramic Sodium Solid-State Batteries – Funding reference O3XP0403A,C,D / 13XP0403B), is funded by the Federal Ministry of Education and Research (BMBF) as part of the Battery 2020 Transfer funding initiative, with total funding of 1.68 million euros.

1. Model of a pouch cell with cathode, polymer-ceramic solid electrolyte and sodium metal anode.



©Fraunhofer IFAM

SIB:DE



©SIB:DE

2

Global demand for high-performance, long-lasting, cost-effective, and safe batteries is increasing. Batteries represent a key technology. However, equipping all application areas with batteries requires very large quantities of raw materials, which could lead to shortages in the medium term. Therefore, the German Federal Ministry of Education and Research is also funding alternative battery technologies based on new materials. The research activities of Fraunhofer ICT and its consortium partners represent an important milestone in the development of alternative battery storage systems in Germany and Europe, featuring safe, resource-efficient, and long-lasting batteries.

The scarcity of key raw materials, along with their sometimes ecologically and socially questionable extraction, is also driving the search for alternative materials such as sodium. While sodium batteries can store less energy per unit volume and mass than conventional lithium-ion batteries, this limitation is of minor importance in stationary applications. Furthermore, most established large-scale batteries for stationary storage are based on lithium-ion technology with flammable liquid electrolytes. This necessitates relatively complex thermal management systems, especially during rapid charging and discharging. The “HyPerium” project therefore utilizes a sodium-based solid electrolyte, which enhances battery safety. A cost-effective solid-state sodium battery is being developed, with consideration given to the entire value chain, from material synthesis and cell construction to model-based optimization.

Fraunhofer ICT produces various solid electrolytes based on polymers or polymer ceramics, as well as cathodes. The sodium-ion-conducting ceramics for the polymer-ceramic solid electrolytes and alternative cathode active materials are developed at IEK-1 of the Jülich Research Centre. The Helmholtz Institute Ulm (HIU) develops the corresponding anodes and alternative polymer electrolytes. The anodes, various solid electrolytes, and cathodes are assembled into laboratory-scale batteries, and their performance is investigated. Battery performance is further improved through modeling of the electrodes and solid electrolytes, battery simulation, and characterization of the cathode materials at the Institute for Mechanical Process Engineering and Mechanics (MVM) at KIT. At ICT, the safety of the battery cells is tested and evaluated. Based on the insights gained during the course of the project, a hybrid polymer-ceramic sodium solid-state demonstrator battery is being constructed.

BMBF Project Launched for Fast Industrial Implementation of Sodium-Ion Technology

The project “Sodium-Ion-Battery Deutschland-Forschung – SIB:DE FORSCHUNG,” funded by the Federal Ministry of Education and Research (BMBF), aims to evaluate the suitability of sodium-ion battery technology (SIB) for the European energy and mobility transition in order to accelerate industrial implementation. To this end, 21 national partners from science and industry are pooling their expertise, ranging from battery material development to the production of large-format cells, to enable the rapid transfer of research results into practical applications.

Battery cells are an indispensable component of the mobility transition agreed upon by the European Union for 2030. They also play a crucial role in integrating large quantities of renewable electricity into the grid and are essential for ensuring an uninterrupted power supply when establishing 5G telecommunications infrastructure.

Lithium-ion batteries are currently the most widely used energy storage systems. However, the dependence on and scarcity of raw materials pose significant challenges for the lithium-ion battery market. Comparable alternatives are therefore urgently needed for both mobile and stationary energy storage systems. Sodium is regarded as a particularly non-critical raw material, as it is readily available, inexpensive, and classified as highly safe. Sodium-ion batteries can therefore play a key role in ensuring a stable and sustainable European energy supply.

Long-term stability and high energy density as a development goal:

When using alternative raw materials, it is important to optimize both the long-term stability and the practical realization of the theoretical energy densities of the materials

1. Lab-scale precipitation reactor for the development of an active material for sodium-ion batteries.
2. SIB:DE project logo.



© ZSW Ulm

and cells used in sodium-ion technology, in comparison with conventional developments, in order to ensure the required performance.

Despite their similar electrical properties, lithium and sodium cannot simply be substituted for one another. Chemical differences between these elements currently lead to technical challenges that result in faster aging of sodium batteries and reduced performance. The “SIB:DE FORSCHUNG” project therefore aims to identify SIB active materials that can be produced in a scalable manner while offering competitive cell performance. In addition, the development of SIB cell demonstrators and the evaluation of the technology’s drop-in capability — which enables integration into existing lithium-ion battery production processes — are of particular importance. This will facilitate the transition to the new technology while reducing production costs and development time. To evaluate the results, an assessment matrix will be developed that takes technological, economic, and ecological factors for different material systems and processes into account.

More added value through strong partners:

The project consortium of the “SIB:DE FORSCHUNG” project consists of seven industrial partners and 14 academic partners, as well as an extended network currently comprising 42 associated partners from science and industry. This makes it the largest consortium in Germany dedicated to this topic. BASF is coordinating the overall project. Only through close collaboration between scientific and industrial expertise can the rapid transfer of research results to industrial scale-up and the swift market penetration of sodium-ion technology be achieved.

While the academic partners are working on topics related to materials science and cell technology, the industrial partners are focusing on scaling up materials and developing industry-oriented cell formats. At the conclusion of the project, the work will result in a recommendation regarding the feasibility of an industrializable process. These results will then serve as a direct interface to the production-related topics and industrial formats targeted in the planned follow-up project on production research, “SIB:DE ENTWICKLUNG.” The overarching goal of the overall project is to establish a comprehensive ecosystem for the production of sodium-ion batteries.

Through its activities, the entire “SIB:DE initiative” represents a significant step toward sustainable and independent battery development in Europe and contributes to overcoming the challenges associated with electromobility and renewable energy systems.

1. Pilot plant for the production of active materials for sodium-ion batteries.



©Fraunhofer IFAM

SOLID-STATE BATTERIES (SSB)



Solid-State Batteries: Next-Generation, High-Energy Storage Systems

Rechargeable solid-state batteries are regarded as the next generation of high-energy storage systems. Compared to conventional lithium-ion batteries with liquid or gel-like organic electrolytes, they offer numerous advantages. These include higher energy density, improved stability, and, above all, increased operational safety. Where cooling systems and additional safety technologies, such as fire protection, can be avoided, significantly simplified system solutions can be developed.

A key challenge in the development of solid-state batteries is increasing their energy content. On the one hand, materials and processes must be identified that enable stable interfaces with low transition resistances. On the other hand, the implementation of innovative electrode architectures and cell designs is essential. The production of batteries consisting exclusively of solid materials presents challenges both at the cell level and for the overall battery system. This requires the use of new manufacturing and production techniques, as well as innovative methods for cell assembly.

To address these challenges, the Fraunhofer institutes offer extensive expertise and many years of experience in the fields of material development, component production, cell assembly, and system design. In addition to material selection, a particular focus is placed on the development of suitable process technologies for the industrial production of solid-state battery cells. System integration also represents a central area of research.

ACTIVITIES IN THE FIELD OF SOLID-STATE BATTERIES

Fraunhofer Center for Electrical Energy Storage and Systems ZESS (Fraunhofer ZESS)

At Fraunhofer ZESS, the entire value chain of solid-state batteries is investigated, from materials to systems, including associated production and recycling management. To this end, a joint infrastructure has been established by pooling the research and development expertise of three Fraunhofer institutes. Fraunhofer ZESS therefore represents a strategic addition to battery research within the Fraunhofer-Gesellschaft, both in Germany and internationally.

FESTBATT Cluster

Cluster of Competence for Solid-State Batteries.

Fraunhofer is Involved in Various Projects:

- FB2-Hybrid: H8 – Fraunhofer ISIT
- FB2-Oxid: O2 – Fraunhofer IKTS
- FB2-Prod: Pr6 – Fraunhofer IST, Pr7 – Fraunhofer IFAM, Pr8 – Fraunhofer IKTS, Pr9 – Fraunhofer IWS
- FB2-SiSuFest: Si2 – Fraunhofer IWS
- FB2-Thio: T5 – Fraunhofer IST, T6 – Fraunhofer IFAM, T7 – Fraunhofer IWS



©Fraunhofer IFAM

©Fraunhofer IFAM

1

PROJECT EXAMPLES

Flexible Solids Recycling - ZDB 2.0

As part of the S-TEC initiative, the Center for Digitalized Battery Cell Production (ZDB) aims to consolidate scientific expertise in battery production at the Stuttgart site. The ZDB infrastructure will form the basis for acquiring and implementing customer-specific development projects along the entire battery value chain.

A key focus is the development of a format- and material-flexible solid-state cycle on a laboratory scale. The flexible design of the solid-state battery production technology enables scalability of the cell format, allowing the realization, analysis, and evaluation of advanced cell concepts such as button, pouch, and cylindrical cells.

Furthermore, enclosing the entire laboratory line within a protective gas atmosphere enables high material flexibility, which is particularly important when selecting suitable solid electrolytes. In addition to developing efficient solid-state batteries, this project also focuses on transferring commercial battery production technologies to solid-state batteries. This will enable the rapid and cost-effective implementation and scaling of the results for industrial-scale production of solid-state batteries.

By integrating dismantling and recycling processes, the laboratory line is operated as a closed cycle.

Safe and Powerful Solid-State Batteries Based on Polymers and Sulfides for Electric Cars, Air Taxis, Mobile Robots and Co.

Solid-state batteries are an important building block for the electrification of mobility. They are safer and enable higher range and shorter charging times than conventional Li-ion batteries. New cell concepts allow even higher energy densities. Fraunhofer IFAM is developing polymer- and sulfide-based solid-state batteries for various electric mobility applications. The research is oriented toward industrial battery production and ranges from the development of new materials for solid electrolytes and battery components (electrodes and separators) to manufacturing process steps and cell assembly.

Advantages of solid-state batteries

The development of solid-state batteries based on lithium-ion technology promises higher energy densities of up to 500 Wh/kg (or 1000 Wh/L), as well as fast-charging capability and intrinsic fire safety. This is achieved by replacing the flammable liquids (organic electrolytes) currently used in batteries with ion-conducting solid materials. Due to their chemical resistance, solid ion conductors enable the use of high-energy materials such as metallic lithium and also provide longer service life.

Another advantage of batteries with solid electrolytes is the feasibility of new space- and weight-saving cell concepts. In addition to the construction of bipolar interconnected cells as a new cell design, the shape of the battery can also be freely selected. This opens up the possibility of using batteries not only as energy supplies and passive structural components in mobile systems, but also of integrating them directly as active structural elements (structural batteries).

New materials for the battery

The range of solid materials used as electrolytes in solid-state batteries is broad and can generally be divided into three groups:

- Polymers or organic electrolytes
- Sulfides or thiophosphates
- Oxides

Fraunhofer IFAM mainly focuses on the first two material classes, since their production and processing do not require high-temperature steps (sintering), unlike oxide-based systems.

1. Components of a polymer electrolyte.



©Fraunhofer IFAM

1

©HDR GmbH

2

Polymeric solid-state batteries are mostly based on thermoplastic systems and therefore offer the advantage of compatibility with long-established manufacturing technologies such as extrusion, injection molding, and calendaring. However, the comparatively lower ionic conductivity and corresponding lower performance remain challenging.

Solid-state batteries based on sulfide ion conductors, on the other hand, exhibit ionic conductivities comparable to those of liquid electrolytes and are therefore suitable for high-power applications. These materials are relatively soft and therefore enable fabrication using conventional solvent-based coating techniques. A disadvantage of such systems, however, is the sensitivity of the materials to moisture.

Applications in electric mobility

The wide variety of possible solid-state battery concepts enables battery cells to be tailored precisely to specific applications.

Polymer-based solid-state batteries are already being used in public transport systems such as buses, where a constant load profile can be predicted due to fixed routes and lower speeds.

In the future, electric cars may also be equipped with high-performance solid-state batteries. In such applications, batteries with both high energy density and high power density are required due to individual driving behavior and higher driving dynamics.

For the emerging electrification and individualization of air travel (air taxis), solid-state batteries offer a space- and weight-saving alternative with a robust design. The intrinsic thermal safety of solid-state batteries also enables a reduction in thermal management requirements.

Their long service life and low maintenance requirements additionally make solid-state batteries attractive for Autonomous Guided Vehicles, including robots and drones.

Process development for series production

Since 2018, Fraunhofer IFAM has been working on processes for the series production of solid-state batteries at the Project Center for Energy Storage and Systems ZESS in Braunschweig, Lower Saxony, Germany. A new research building is currently under construction there.

The enclosed dry room enables the evaluation of different process technologies ranging from material synthesis to cell assembly. Current activities focus on the scaled production of sulfide electrolyte materials and the processing of polymer electrolytes. Continuous progress in cell development is steadily advancing the manufacturing of battery cells.

1. Charging station for electric cars at Fraunhofer IFAM.

2. New research building of the Fraunhofer Project Center for Energy Storage and Systems ZESS.



©Fraunhofer ISE

1

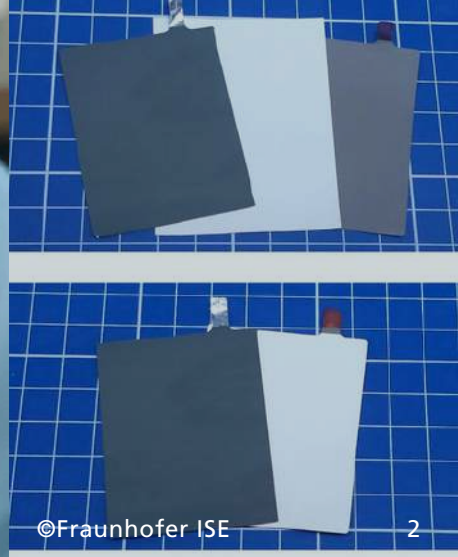

©Fraunhofer ISE

2

All-Solid-State Batteries

The All-Solid-State Battery (ASSB) is considered a disruptive concept that enhances safety, performance, and energy density compared to current lithium-ion battery cell technologies. By eliminating the need for liquid electrolytes, ASSBs also enable the implementation of entirely new cell concepts and integration strategies.

Fraunhofer ISE's research activities in the field of ASSBs range from the development of tailor-made electrode materials and the manufacturing of battery cell components — including separators and electrodes — to the assembly of complete battery cells.

Based on its experience and techno-economic evaluations in the field of lithium-ion storage systems, Fraunhofer ISE focuses primarily on the use of sulfide electrolytes in ASSBs. This class of materials enables high lithium-ion conductivities at room temperature (10^{-3} – 10^{-2} S·cm⁻¹) without the need for additional liquid electrolytes. Similar to polymer solid electrolytes, sulfide electrolytes combine the material properties required for industrial processing with low crystalline density, thereby enabling high energy densities (> 400 Wh·kg⁻¹ / > 1000 Wh·l⁻¹) using conventional cathode materials such as NMC-based materials (e.g. LiNi_{0.8}Mn_{0.1}Co_{0.1}O₂).

Fraunhofer ISE's R&D services in the field of "All-Solid-State Batteries" include:

- Tailored active materials for All-Solid-State Batteries
- Manufacturing of electrodes and separators
- Cell assembly and characterization of All-Solid-State Batteries
- Development of demonstrators and production technology validation for ASSB concepts

Tailored Active Materials for All-Solid-State-Batteries

Active materials are an essential component of every battery cell. Fraunhofer ISE focuses intensively on the synthesis and refinement of novel and sustainable active materials, with particular emphasis on customizing materials to meet the requirements of ASSB cells.

The institute's R&D offerings in this area include:

- Refinement of active materials through pre-lithiation and/or surface coating
- Development and scaling of tailored high-energy-density active materials, including cobalt-free NMC-like materials and their lithium-rich variants
- Blending of active materials and solid electrolytes using established milling procedures or customer-specific adapted processes at different scales
- Characterization of materials using in-house measuring instruments

Manufacturing of Electrodes and Separators

Fraunhofer ISE pursues two strategic methods for the manufacturing of ASSBs. The production of individual components — cathodes, separators, and anodes — for self-standing designs enables replication of established lithium-ion battery production processes and allows investigation of drop-in replacement concepts for accelerated market introduction. In the two-component design approach, the separator is applied directly onto an electrode, enabling the production of ultra-thin separators below 15 μm.

The institute's R&D offerings in this area include:

- Supply of in-house-manufactured electrodes (NMC cathodes and silicon anodes) with areal loadings of 0.5–4 mAh·cm⁻² for external investigations, with compositions adjustable according to customer requirements
- Production of solid-state separators (20–50 μm) using in-house-developed infiltration processes for scaffold-supported self-standing products or bilayer-cast designs applied directly onto cathodes or anodes
- Design of slurry recipes at liter scale for the production of ASSB electrodes and separators

1. Silicon powder before (right) and after (left) prelithiation.
2. At Fraunhofer ISE, manufactured electrodes and separators used for the assembly of self-standing (top) and bilayer cast (bottom) designs.

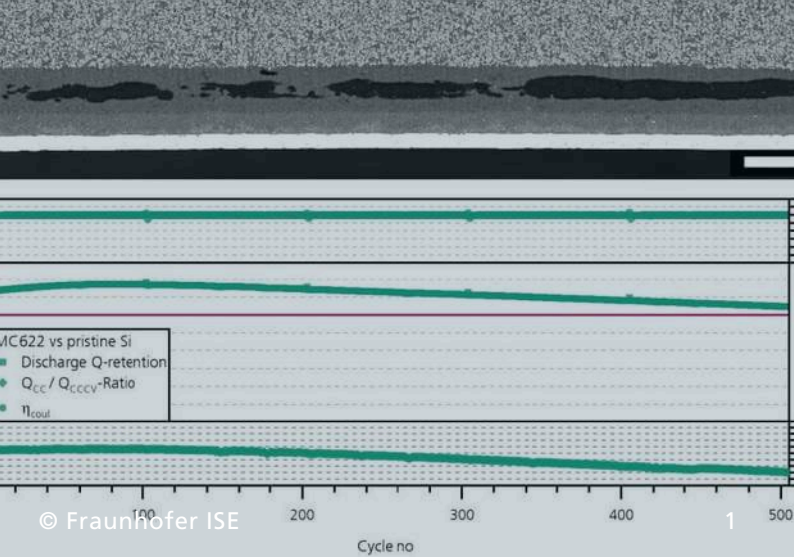

Cell Assembly and Characterization of All-Solid-State-Batteries

Fraunhofer ISE investigates the complete lifecycle of ASSB cells, from microstructural changes during component joining to performance testing and end-of-life analysis. Each individual process step can be examined within the institute's facilities.

The institute's R&D offerings in this area include:

- Testing of ASSB components and materials in different cell formats, including coin, pressure, and pouch cells
- Investigation of manufacturing parameters such as temperature, pressure, and atmosphere during ASSB cell assembly
- Electrochemical analysis, including cycling stability, performance testing, and cell impedance measurements
- In operando analysis of pressure and temperature dependencies
- Post-mortem analysis, including microstructural investigations of battery cell cross-sections

Development of Demonstrator and Production Technology Validation for ASSB Concepts

As ASSB technologies move closer to industrial production readiness, Fraunhofer ISE's dry-room facility and pouch-cell pilot line enable the assembly and investigation of ASSBs in commercially relevant formats.

The institute's R&D offerings in this area include:

- Technical evaluation of cell chemistry and production processes for solid-state batteries
- Production of single-layer and multilayer pouch cells according to customer requirements
- Provision of single-layer and multilayer pouch cells using Fraunhofer ISE's own components for external investigations
- Support for development projects involving the integration of solid-state batteries

1. Cross-section of an ASSB assembled using the self-standing design (top). Cycle stability plot (bottom) of an ASSB cell experiencing a rapid aging protocol (charging time to reach SoC = 80 %, < 10 min).
2. CAD-model of Fraunhofer ISE's demonstrator multilayer ASSB pouch cell design (format: 169 x 96 cm²).



© Fraunhofer IFAM

1



© Fraunhofer IFAM

2

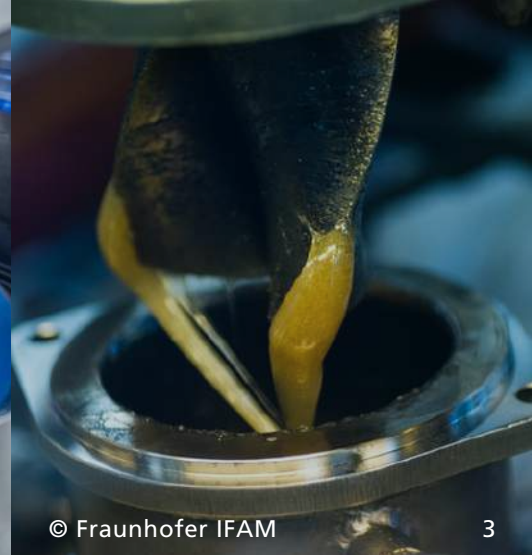

© Fraunhofer IFAM

3

Battery Laboratory for the Development of Solid-State Batteries

TECHNOLOGIES FOR PROCESSING OF SOLID-STATE BATTERY MATERIALS AND CELL ASSEMBLY UNDER INERT ATMOSPHERE (GLOVEBOX)

Currently, the automotive industry in particular is focusing on solid-state batteries for electric vehicles. New materials and manufacturing processes are required for the development of rechargeable batteries based on solid-state technology, in which solid electrolytes are used instead of liquid electrolytes. Fraunhofer IFAM is investigating various techniques for the development and processing of raw materials, as well as the cell assembly of solid-state batteries. In the battery laboratory, all methods can be applied in a micro-environment using a glovebox under inert atmosphere.

Technologies for Every Step of Battery Development

The battery laboratory at Fraunhofer IFAM provides suitable technologies for every step of battery development:

Material development

- The selection of suitable materials is crucial for the successful development of a solid-state battery. In addition to selecting appropriate storage materials/active materials, the correct use of additives such as conductive additives and binders is particularly important.
- For the evaluation of individual materials (binder systems) in combination with other components, Fraunhofer IFAM relies on extensive chemical analytical methods (NMR, XPS, XRD, SEM), which allow sample transfer under inert conditions, as well as electrochemical methods.
- Karl Fischer titration is used for quality control of the starting materials.

Slurry/composite development

- For the preparation of solvent-based dispersions (pastes/slurries) used in the production of coating compounds, different mixing systems such as stirrers with various mixing heads and mixers (intensive mixers, paddle mixers) are available. Alternatively, a three-roll mill can be used for homogenization.
- A twin-screw extruder is available at Fraunhofer IFAM for the evaluation of innovative solvent-free mixing processes.
- In parallel with formulation development, analytical methods are available for determining essential process parameters (such as viscometry and surface tension) under argon atmosphere.

Coating technology for component development

- The production of individual battery components (cathode and electrolyte/separator) on a small scale for material evaluation is carried out using automatic film applicator and doctor blade technology. Different widths and film thicknesses are achieved using various doctor blades.
- For the application of thin films on a larger scale, a sheet-to-sheet slot-die coater is available.
- Screen-printing equipment is available as an alternative technique for the production of solid-state batteries.

1. Twin-screw extruder under inert conditions.
2. Eirich-mixer for large-scale slurry preparation.
3. Femix-mixer for dry processing of thermoplastic polymers.



© Fraunhofer IFAM

1



© Fraunhofer IFAM

2



© Fraunhofer IFAM

3

- A glovebox is equipped for physical vapor deposition (PVD) for the application of thin lithium-metal anodes, as well as the deposition of intermediary layers in Li-free cell concepts.

Cell assembly (Pressing, Calendering, Compaction)

- For the performance of solid-state batteries, the joining of the individual layers represents a significant process step. For this purpose, hydraulic presses and a laboratory calender are available for cell assembly. The applied pressure can be detected in a spatially resolved manner.

Measurement technology

- Several potentiostats and cell test systems are available for electrochemical characterization. The tests can be conducted under controlled environmental conditions.
- For post-mortem analysis, scanning electron microscopy (SEM) under inert conditions is employed.

Glovebox: Manufacturing of Solid-State Batteries in Micro-Environment

Many materials considered for use as electrolytes in solid-state batteries are not stable under normal ambient conditions. They are either hydrophilic, meaning they absorb water from ambient air, or they react directly with water or oxygen. This leads to reduced performance in the final battery and must be avoided during cell assembly. To protect sensitive materials from moisture and air, they are handled in micro-environments under inert gas (argon). Working in gloveboxes enables precise control of environmental conditions, which can later be transferred to the requirements of scaled production processes. In this context, the key question being addressed is whether battery cell production should take place in micro-environments or in large dry rooms from both economic and ecological perspectives.

EXEMPLARY APPLICATIONS OF THE TECHNOLOGIES IN BMBF PROJECTS

Alternative Anode Concepts for Safe Solid-State Batteries - ALANO (BMBF):

The tasks of Fraunhofer IFAM within the sub-project "Processing, Manufacturing and Recycling of Lithium-Metal Solid-State Batteries" include, on the one hand, the production of cell components such as separators and composite cathodes based on sulfide ion conductors and, on the other hand, full-cell assembly using the anode systems developed by project partners. The cell components are successively adapted based on the knowledge gained during the overall project. In addition to the type and quantity of polymer binders used, process techniques are also optimized to improve the microstructure and mechanical properties. Subsequently, full cells are produced in the form of pouch cells employing the lithium-metal anodes developed within the project. The aim is to evaluate both possible cell designs (e.g. monopolar/bipolar) and the necessary operating conditions (temperature and pressure).

Continuous, Solvent-Free Electrode Production with Intelligent Quality Assurance and Process Monitoring Coupled with AI - KontElPro (BMBF Competence Cluster Intelligent Battery Cell Production - InZePro):

The aim of KontElPro is to extend existing innovative and highly scalable processes for solvent-free electrode manufacturing (extrusion, dry transfer processes) with inline process control and a cross-site, networked database. Fraunhofer IFAM is optimizing extrusion processes for the continuous production of battery components through monitoring and control of process parameters. Within the project, polymer electrolytes are extruded, while process data such as temperature, torque, and pressure are recorded. During the development of a digital workflow, these process data are evaluated together with the project partners.

Cell Platform Thiophosphates - FB2-Thio (BMBF Competence Cluster for Solid-State Batteries - FestBatt):

At Fraunhofer IFAM, the focus of the sub-project "Process Technology for the Production of Thiophosphate-Based Solid-State Battery Cells" (PhatBatt) lies on the

1. Slot die coater under inert conditions.
2. Testing screen printing as an innovative technology for electrode production.
3. Sputtering system integrated in glovebox for PVD processes.



©Fraunhofer IFAM

1

©Fraunhofer IFAM

2

processing of thiophosphate-based separators using scalable methods. In particular, the use of slot-die coating is being pursued as a novel approach. On the one hand, chemically stable and rheologically adapted slurries must be produced, while on the other hand, the process parameters must be evaluated. In addition, this method will also be used directly for cell construction by coating separators directly onto composite electrodes.

Cross-Sectional Platform Production - FB2-Prod (BMBF Competence Cluster for Solid-State Batteries - FestBatt):

The central goal of the project is the research and development of scalable, quality-assured production processes for high-performance solid-state batteries based on the solid electrolytes investigated in the cell platforms. To this end, the consortium is mapping the entire production chain on a small pilot scale, starting with the production of composite cathodes and separators of various material classes using different scalable approaches, through to cell assembly, conditioning, electrochemical characterization, and the economic and ecological evaluation of the complete production process.

At Fraunhofer IFAM, processes for the manufacturing of polymer-based separators are being developed. Both processes for producing free-standing polymer separators and methods for direct application onto composite cathodes are being investigated. Reproducibility is continuously improved throughout the project through the selection of suitable processes (doctor blade, slot die, printing) and adjustment of process parameters (application speed, temperature).

Alternative Process Technology: Solid-State Batteries with 3D Printing Technologies:

3D printing represents a novel process technology for manufacturing battery cell components such as separators, cathodes, and anodes. Based on Fraunhofer IFAM's expertise in additive manufacturing technologies, manufacturing scenarios are being evaluated for the production of solid-state batteries that can be flexibly adapted to demanding installation spaces.

- 1. Calander for compaction and transfer of solid-state cell components.
- 2. Pressure setup for solid-state battery cycling.

Innovations for the Battery of the Future

At Fraunhofer IWS, innovations for the battery of the future are at the center of research activities within the field of Battery Technology. The institute develops new concepts covering the entire process chain of battery cell manufacturing. Research focuses on investigating the structure-property relationships of new materials in battery cells, as well as on developing efficient, cost-effective, and resource-saving production processes.

A central area of research and development at Fraunhofer IWS is the creation of novel coating technologies. The DRYtraec® (Dry Transfer Electrode Coating) process developed by the institute enables the solvent-free, environmentally friendly, and cost-efficient production of battery electrodes. For lithium-metal batteries, Fraunhofer IWS is developing innovative process solutions ranging from the production of thin lithium layers to the automated assembly of cells.

In addition to advancing current lithium-ion technology, research activities at Fraunhofer IWS also focus on innovative energy storage concepts such as lithium-sulfur and solid-state batteries. Furthermore, the institute develops customized solutions for Gas and Particle Filtration to remove harmful substances generated during battery production and recycling.

Through these activities, Fraunhofer IWS offers its partners and customers an R&D platform that spans material and process innovations through to the application-oriented evaluation of new cell concepts.

REFERENCE PROJECTS

Talissman

The TALISSMAN EU Project is a Horizon Europe research initiative developing sustainable lithium-sulphur batteries for electric mobility. The Project is paving the way for a new generation of batteries that are safer, lighter, and more sustainable. Funded by the European Union under the Horizon Europe programme, TALISSMAN focuses on the design and development of advanced lithium-sulphur battery technologies using abundant, low-impact materials such as sulphur.

Unlike conventional lithium-ion batteries, lithium-sulphur cells have the potential to offer higher energy density, lower costs, and a smaller environmental footprint. Through this innovation, TALISSMAN supports Europe's broader transition to clean energy and transport. The future of batteries should be sustainable and accessible to all. TALISSMAN is committed to developing technologies that serve people, industry, and the planet. Read more about the importance of sulphur [here](#).

Impacts:

- **Increased Safety:** Solid and quasi-solid electrolytes with strong interface protection reduce fire risk and prevent failures.
- **Improved Technical Performance:** TALISSMAN develops batteries with up to 550 Wh/kg, enabling lighter, high-efficiency energy storage for aerospace and electric mobility.
- **Superior Cost-Effectiveness:** By using low-cost and abundant materials, TALISSMAN targets costs below €75/kWh by 2030.

Led by CIDETEC Energy Storage, the TALISSMAN EU Project brings together nine leading partners from Spain, France, Germany, and Italy, including Airbus, ARKEMA, Fraunhofer,



©Siegfried Michael Wagner

1



©Fraunhofer IWS

2

and SAFT. The consortium combines expertise in chemistry, engineering, scale-up, and sustainability, ensuring a multidisciplinary pathway toward impact. TALISSMAN's innovations are fully aligned with the European Green Deal, the Strategic Action Plan for Batteries, and the Batt4EU partnership. Through a Safe-and-Sustainable-by-Design approach, the project integrates environmental responsibility, recyclability, and circular economy principles at every stage of the development process. We are building batteries that will help Europe move cleaner, faster, and smarter. processing of thiophosphate-based separators using scalable methods. In particular, the use of slot-die coating is being pursued as a novel approach. On the one hand, chemically stable and rheologically adapted slurries must be produced, while on the other hand, the process parameters must be evaluated. In addition, this method will also be used directly for cell construction by coating separators directly onto composite electrodes.

Lithium Metal Coating Technologies for Future Generation Batteries (LiMeCore)

Clean and cost-effective energy storage is one of the greatest technological challenges facing Europe in the near future. There is an urgent need for high-performance energy storage solutions that go beyond current lithium-ion battery technology. Lithium-metal batteries have proven to be among the most promising concepts for improving energy density and, consequently, the driving range of electric vehicles. Therefore, the lithium-metal anode is a key component for next-generation batteries.

Future cell chemistries require very thin lithium layers that are applied directly onto current collector foils. Furthermore, the surface properties of lithium films have a significant impact on their processability during cell assembly and on cell performance, particularly cycle life and power output. Currently, there is no established concept for processing metallic lithium anodes (layer deposition and surface treatment) that offers a technical pathway toward large-scale production.

The goal of LiMeCore is the development of stable lithium-metal anodes using scalable manufacturing processes. This will be achieved through innovations in interface technology and surface modification, involving an interdisciplinary consortium across the entire process and value chain — from material innovations and in-situ characterization to process development and upscaling, culminating in technology demonstrations in prototype cells. The technologies developed within the project will form a generic platform for processing lithium-metal anodes suitable for both liquid and solid-state batteries.

The LiMeCore consortium, comprising five partners from Belgium, Taiwan, and Germany, is ideally positioned to achieve these ambitious goals through material innovation and characterization, coating process development, interface research, and technology demonstration. The participating partners are already recognized for their scientific research in the field of lithium-metal anodes and, at the same time, offer a pathway toward commercialization through their existing patent portfolio (including patents on lithium melt deposition and plasma treatment) and the involvement of the Max Planck Society (MPG) as an industrial (SME) partner.

If successful, LiMeCore will provide a solution to key challenges in future energy storage and establish the consortium members as competitive innovation drivers with technological leadership made in Europe.

Gradient and Multi-Material Processing of Next-Generation Solid-State Lithium Batteries Using Direct Material Processing (GREEN-BAT)

Rapid global industrial development, population growth, and the associated transportation demands in aviation, aerospace, shipping, and especially automotive manufacturing have led to a dramatic increase in the consumption of fossil fuels. Worldwide, there is an ongoing search for alternative energy sources and storage solutions, with particular focus on motor vehicles. Among the various alternative energy sources, all-solid-state lithium batteries (ASSLBs) represent a promising storage technology characterized by significantly improved safety (e.g. in the event of fire),

1. Lab for material preparation and electrode manufacturing at Fraunhofer IWS.
2. DRYtraec®: Dry-coating technology that massively saves space, costs and chemicals. The process technology at Fraunhofer IWS allows process development up to continuous double-sided coating.

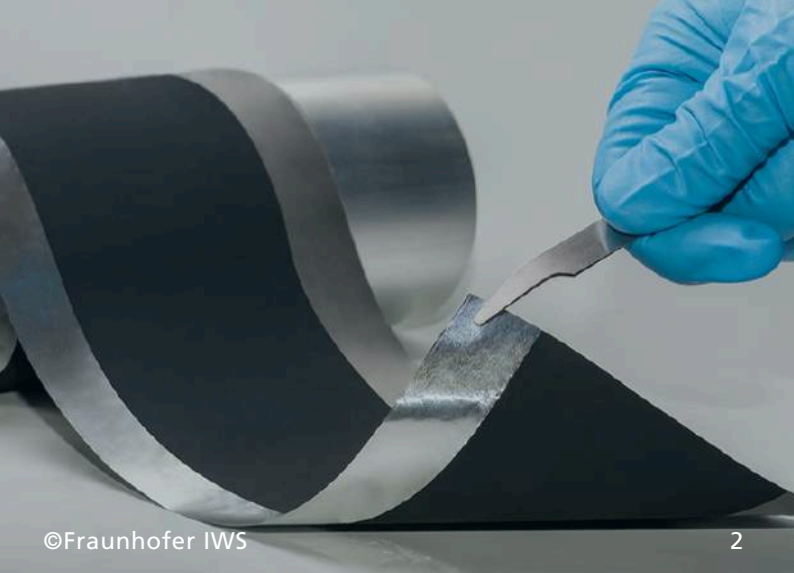
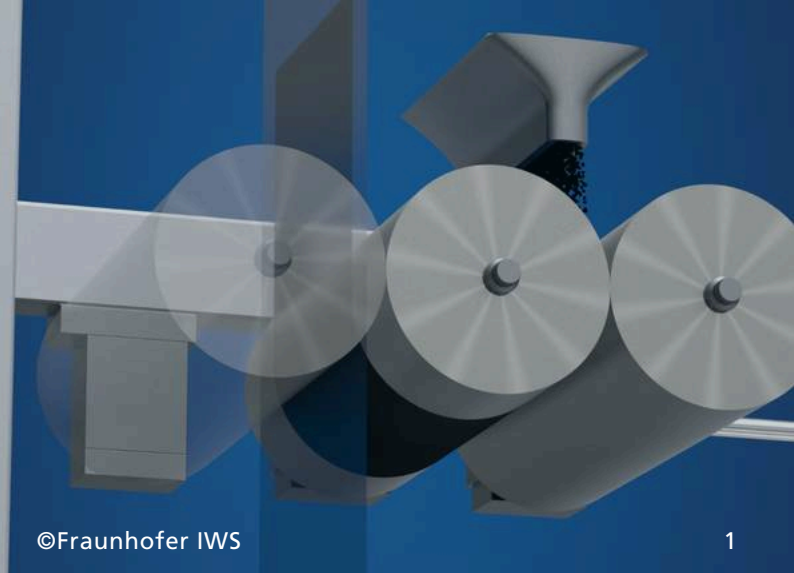

simplified battery cell design, and very high gravimetric energy density. In the past, research on ASSLBs focused on identifying alternative materials, electrode compositions, and especially solid electrolytes, which form the core of ASSLBs. State-of-the-art ceramic solid electrolytes, such as garnets and various sulfides, are now sufficiently conductive, meaning that electrolytes are no longer considered the primary hurdle for ASSLB development. The same applies to anode and cathode materials, which already offer low cost, improved environmental compatibility, and higher cycle stability, even at elevated temperatures.

Despite the availability of suitable electrode and electrolyte materials, the adoption of ASSLBs across various industries remains limited. This is due, for example, to the complex manufacturing of electrodes and the sophisticated technologies required for processing solid electrolytes, such as sol-gel methods, slurry coating using doctor blade deposition, spark plasma sintering, solution-based infiltration processes, vapor deposition, and others. All of these technologies share several common challenges, including high costs, high reject rates, low throughput combined with high energy consumption, and, above all, limited scalability for mass production. Furthermore, all ASSLB components are manufactured in separate process steps, which creates additional logistical and assembly requirements such as pressing and welding.

These are some of the primary reasons why ASSLBs have not yet achieved large-scale implementation. The GREEN-BAT project aims to address precisely these challenges by investigating a novel manufacturing route for lithium-based solid-state batteries using established and scalable multi-material technologies. Laser deposition welding (L-DED) and plasma spraying, which utilize powders and suspensions as feedstocks, will be employed. The project aims to advance this novel concept from Technology Readiness Level (TRL) 2 to TRL 3.

1. DRYtraec process scheme: The shear force in the calender gap leads to film formation on the faster rotating roll. Therefrom, the film is transferred to the target substrate.
2. This is what electrodes coated with the new DRYtraec dry transfer technology look like. The process enables battery electrodes to be produced without toxic solvents on a pilot scale.



BATTERY CELL INNOVATION & PRODUCTION OF PROTOTYPES



© Accenture/Fraunhofer FFB

1

Battery Cell Innovation & Production of Prototypes

Core Competencies

Driving innovation in battery cell manufacturing requires an interdisciplinary approach. Fraunhofer FFB has brought together a team of experts from various disciplines who work collaboratively under one roof. These experts specialize in electrochemistry, process engineering, mechanical engineering, sustainability, and economics. Together, we are united by the goal of shaping the future of the battery industry.

Overview

Fraunhofer FFB's expertise and services cover all key areas of battery cell production, from individual process steps and complete process chains to cross-cutting topics. Eight main areas of expertise can be identified:

- Process Innovation
- Digitized Battery Cell Production
- Battery as a New Business Opportunity
- Battery Cell Innovation & Production of Prototypes
- Material Cycles & Sustainability
- Factory Planning
- Industrialization & Production Management
- Quality in Battery Cell Production

Whether solid-state batteries, sodium-ion batteries, lithium-sulfur batteries, or incremental innovations to existing lithium-ion battery cells, one thing is clear: the development of new generations of cells is advancing rapidly, and new cell types are continuously entering the market. At the same time, significant untapped potential remains in cell design to increase performance and energy density. During the development process, the associated questions and challenges are constantly evolving. Fraunhofer FFB supports customers in the conception, development, prototyping, validation, and evaluation of new battery technologies — from idea generation through to market launch.

New Research Shows Benefits of Digitalization in Battery Cell Manufacturing

Digitalization makes the production of batteries for electric vehicles more cost-effective and environmentally friendly. This is a key finding of a new research report presented by Fraunhofer FFB and Accenture at Hannover Messe 2024. By leveraging digital solutions, a battery cell factory with an annual production capacity of 40 gigawatt hours can save up to 27 million euros and reduce emissions by nearly 10% per year.

One example is the scrap rate — the proportion of materials and batteries that cannot be used or sold due to quality defects. High scrap rates are a well-known challenge in battery cell manufacturing. Digital predictive quality and traceability solutions can reduce these rates by up to 10.3% compared to conventional production methods. Since materials account for more than two-thirds of total battery cell production costs, digital solutions are particularly effective in reducing both costs and waste.

Driving efficiency with digital technologies

Another example is energy consumption, which accounts for approximately 5% of total battery production costs. Through digital tracking and optimization solutions, manufacturers can reduce energy consumption by up to 9.5%. These solutions can also help avoid up to 9.7% of emissions generated during the production process. A third example is machine downtime, which digital predictive maintenance applications can reduce by up to 7.1%.

"The comprehensive digitalization of the value chain is a key enabler for more sustainable battery production," says Dr. Jonathan Krauß, Interim Head of Digitalization in Battery Cell Manufacturing at Fraunhofer FFB. "Digital investments demonstrate clear economic benefits, particularly through the reduction of production costs. The challenge for battery manufacturers lies in identifying the right technologies and investing in them at the appropriate time."

Digital solutions are expected to provide particular benefits for electrode production, as the majority of materials are used during this first stage of battery cell manufacturing.

"Efficiency and quality are critical in battery production, especially in Europe, where a new industry is being established under high cost and time pressure," says Dr. Philipp Wunderlich, Senior Manager and Battery Technology Lead at Accenture. "By leveraging advanced digital technologies, we have the opportunity to secure a competitive advantage. However, manufacturers still need to catch up in terms of digitalization, even with more fundamental applications such as data collection and real-time analytics, which are prerequisites for benefiting from transformative technologies such as generative AI."

1. Study shows benefits of digitalisation in battery cell production: Millions in savings and emissions reductions possible.



© Fraunhofer ISE

1



© Fraunhofer ISE

2

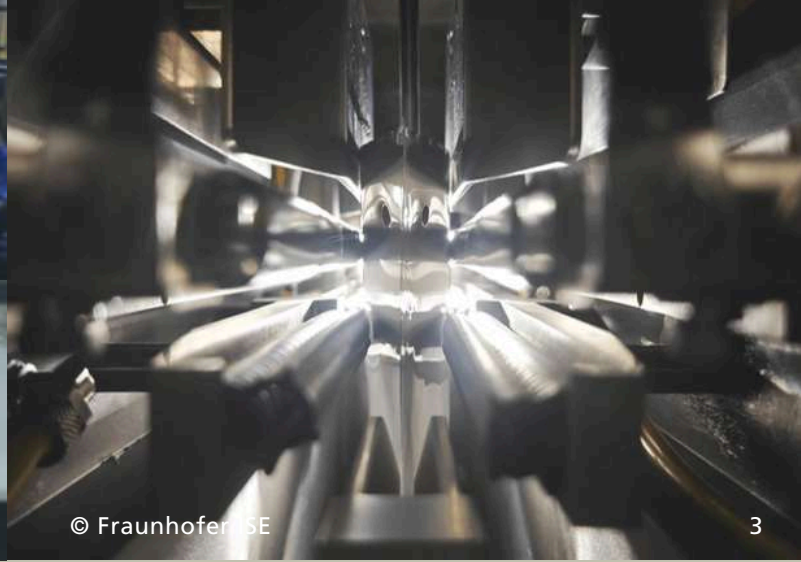

© Fraunhofer ISE

3

Battery Cell Production

In addition to electrode manufacturing and cell finalization, Fraunhofer ISE's research activities focus on cell assembly, which plays a key role in battery cell production. This involves a range of processes used to produce finished battery cells from individual materials such as electrodes, separators, housing materials, tabs, and electrolytes. Alongside the materials themselves, the manufacturing processes, their precision, and the atmospheric conditions during processing, including particle contamination and humidity, have a significant influence on battery cell performance in terms of aging behavior, safety, energy density, and power density.

Within Fraunhofer ISE's pilot line for battery cell production, materials pass through seven process stations from start to finish. Electrodes are first separated from electrode foils or individual electrodes using high-precision mechanical punching. The separated electrodes and separator materials, available either as foils or individual sheets, are subsequently assembled into a cell stack through either a continuous Z-folding process or single-sheet stacking. Automatic placement within a cell-stack holder ensures precise alignment of the electrodes.

The lead tabs are then connected to the current collectors of the electrodes by ultrasonic welding. In the next process step, pouch composite films serving as housing materials are cut to size and deep-drawn to produce the half-shells for the cell stack. After insertion of the cell stack, the housing is sealed on three sides using a heat-sealing process. The cell is subsequently filled with electrolyte inside a vacuum chamber and sealed under defined vacuum conditions using impulse sealing. The gas generated during the battery cell formation process can then be removed within the vacuum chamber, resulting in the completion of a new battery cell.

With its pilot line and infrastructure, Fraunhofer ISE addresses the following technical requirements for cell assembly:

- Optimally adjusted system and process parameters depending on the materials used
- High manufacturing precision, particularly during stacking
- Low particle contamination in the atmosphere (clean room class ISO 7)
- Dry atmosphere conditions with dew points down to -55 °C, corresponding to approximately 0.08% relative humidity

Assembly of Pouch Cells

Using its cell production line, Fraunhofer ISE manufactures pouch cells with electrode formats ranging from 50 × 50 mm² to 200 × 200 mm² (standard format: 120 × 70 mm²) as both single-layer and multilayer cells. The institute's flexible production capabilities enable the testing of a wide range of materials, including active materials, binders, conductive additives, separators, electrolytes, housing materials, and lead-tab materials, in commercial battery-cell formats under controlled atmospheric conditions.

The cell stack is assembled fully automatically with high electrode placement accuracy using either continuous Z-folding or single-sheet stacking. The pouch cell is completed through ultrasonic welding of electrodes and lead tabs, pouch-film preparation including deep drawing, heat sealing of the pouch film, and electrolyte filling within a vacuum chamber. Following a defined wetting period, the cell undergoes formation under defined axial pressure and is subsequently cycled after degassing.

Process Optimization in Cell Assembly

Fraunhofer ISE offers process optimization across all stages of cell production. In the mechanical punching stage, for example, web-edge quality can be visually inspected following the punching process. In stacking operations, the institute validates the gripping and holding properties of Bernoulli and vacuum suction grippers while also testing the processability of different separator materials.

Optimization is also performed in ultrasonic welding through the adjustment of parameters such as pressure, energy, and process time.

Production Technology for Batteries

Fraunhofer ISE focuses on procedures, processes, and technologies and their application in the manufacture of energy storage systems. The institute's objective is to increase the safety, quality, and performance of batteries while simultaneously optimizing production technologies. Its expertise is directed toward material, cell, and module manufacturers, plant and mechanical engineering companies, factory planners, and research institutes.

Fraunhofer ISE develops innovative processes for the production of battery materials with high purity and homogeneity. In addition, the institute manufactures electrodes with precise microstructures in order to enhance battery performance.

The institute's activities focus on process development and optimization for the production of high-performance battery materials, as well as on research into manufacturing technologies for all-solid-state batteries aimed at improving energy density, safety, and service life. Fraunhofer ISE's manufacturing technologies for pouch cells enable the production of industrially relevant cells for a wide range of energy storage applications within a production-relevant environment.

1. Fully automated stacking with z-folded separator.
2. Ultrasonically welded stack of graphite anodes and anode lead tab.
3. Electrolyte filling of the pouch cell in a controlled atmosphere and under specifically set vacuum pressure.



Fields of Work

- Particle Refining by Powder Processing Techniques
- Wet and Dry Electrode Manufacturing and Thin-Film Technology
- Battery Cell Production (Pilot Production for Pouch Cells)
- Fabrication Technology for Solid-State Batteries
- Energy-Efficient Clean and Dry Rooms
- Cell Connection Technologies for Battery Modules

R&D Infrastructure

For Fraunhofer ISE's battery research and development activities within the "Center for Electrical Energy Storage", we have an area of 5,500 m² at the institute's disposal. Of this, 1,300 m² is fully equipped laboratory space dedicated to cell development and production technology, including:

- Industrial dry room (ISO 7) with 125 m² of usable space and dew points down to -60°C
- Additional dry rooms with 120 m² of usable space and dew points down to -40°C
- Demonstrator test stand for a mini-environment (flow-flexible, variable dew point down to -65°C, variable ambient humidity) (currently under construction)

For composite films, both deep-drawing behavior and sealing properties can be optimized by adjusting parameters including hold-down pressure, speed, depth, acceleration, deceleration, sealing temperature, sealing time, and pressure.

During electrolyte filling, the vacuum chamber can be flushed with different inert gases such as argon or nitrogen. Pressure profiles for filling and degassing can be flexibly adjusted within defined safety limits, while single-stage and multi-stage filling processes enable the investigation of different electrolytes, for example as part of electrolyte studies.

Characterization, Post-Mortem Investigations, and Safety Tests

Fraunhofer ISE's characterization capabilities for pouch cells include electrochemical testing for aging and performance behavior, high- and low-temperature testing, and electrochemical impedance spectroscopy (EIS). Pouch cells are axially pressurized within modular cell carriers, while formation and cycling are carried out in climate chambers.

The institute's characterization equipment also enables mechanical testing of battery materials such as electrodes, separators, and housing materials with respect to adhesion, tensile strength, peel strength, and additional mechanical properties.

In addition, Fraunhofer ISE can quantitatively determine the expansion of pouch cells during current application in both uniaxial and three-dimensional configurations using specialized test equipment.

Beyond electrochemical and mechanical testing, the institute also performs post-mortem investigations on pouch cells after they reach their defined service-life limits. These investigations include the analysis of deposits on electrode materials and changes within the electrolyte. Reinforced bunker rooms additionally enable safety-critical testing such as overcharging, overheating behavior, and mechanical abuse testing.

Digitization and Traceability in Cell Production

Fraunhofer ISE utilizes a specially developed digitalization solution to track and store machine and process data from cell assembly equipment, as well as infrastructure data from dry rooms, including dew point measurements, in real time. These parameters can be provided upon request and following prior clarification.

To document materials across all levels, from electrical cell parameters to active mass fractions within electrodes, Fraunhofer ISE is currently developing and implementing a "track & trace" solution that enables materials to be labeled and subsequently scanned throughout the process chain.

Validation of New Battery Technologies and Sensor Concepts

Fraunhofer ISE's pouch-cell production line also enables the validation and testing of emerging battery technologies and their associated materials. Since sodium-ion technology is considered a drop-in technology relative to lithium-ion technology, sodium-ion pouch cells can be manufactured and characterized rapidly and without major modifications to existing lithium-ion production lines. In addition, (all-)solid-state pouch cells can also be manufactured using the same infrastructure.

Beyond new cell chemistries, the institute also offers the possibility to validate innovative sensor concepts within an industry-oriented production environment. All process steps and equipment, from mechanical electrode separation to electrolyte filling, are available for this purpose.

1. Cycling of Fraunhofer ISE's pouch cells under specific axial pressure.
2. Doctor blade coating of a hard carbon anode on an aluminum substrate for a sodium-ion cell.

Battery manufacturing at Fraunhofer IPA

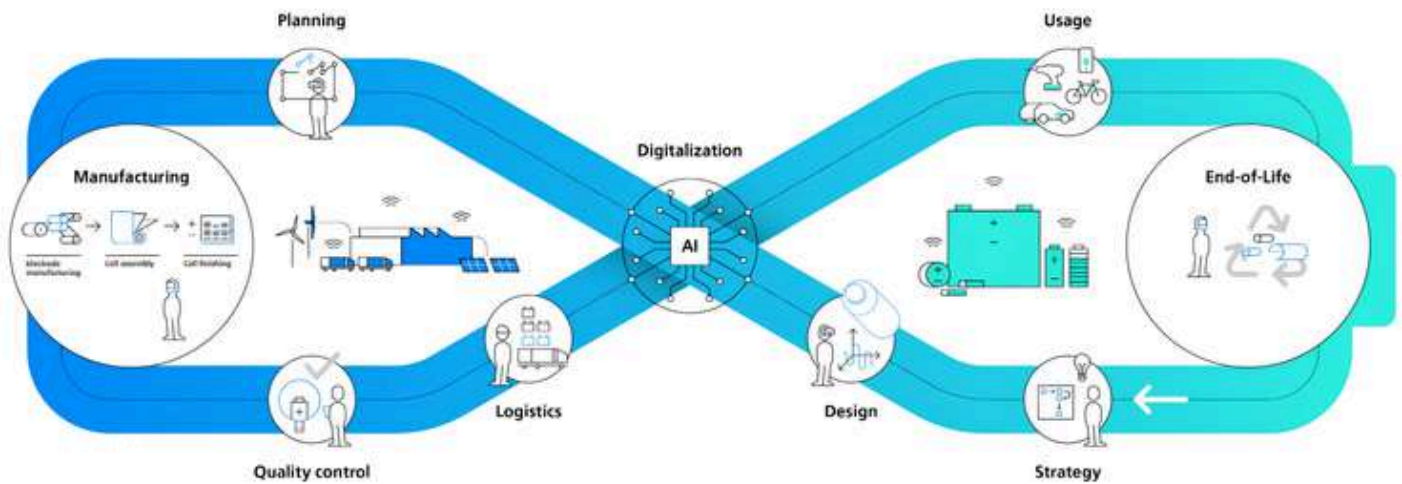

Battery Manufacturing

Drive batteries account for a large proportion of the added value in the manufacture of electric vehicles. The battery cell is a key technology and is therefore of central importance. Manufacturing battery cells in Europe and Germany in the future is both a political objective and an economic necessity. This can only be achieved through the planning and construction of climate-friendly giga-factories for the production of high-quality battery cells. End-to-end digitalization of the value chain will not only provide decisive competitive advantages but also serve as a unique selling point. At the Center for Digitalized Battery Cell Manufacturing (ZDB), methods and tools for this purpose are being developed and extensively tested on a laboratory production line.

Digitizing the entire value chain in battery cell production is one of the core tasks of the Center for Digitalized Battery Cell Manufacturing (ZDB). Research services support the certification and scaling of existing lithium-ion and future battery cell concepts and manufacturing processes. The focus is always on stabilizing and improving product quality while taking strict economic and ecological constraints into account.

To achieve this, ZDB optimizes individual production processes, complete interconnected production lines, and higher-level process and building infrastructures. In the future, the Center for Digitalized Battery Cell Manufacturing at Fraunhofer IPA will include a fully digitized production chain for lithium-ion battery cells.

BATTERY MANUFACTURING AT FRAUNHOFER IPA

Electrode Manufacturing

Flexibility and variability are essential for the development of new energy storage systems in order to keep investment and operating costs low. At the same time, each process step must be systematically investigated from a research perspective. To address this, the "Functional Materials" department at Fraunhofer IPA has combined the process steps required for manufacturing small quantities with variable designs within its technical center, "Flexible Battery Production".

The scalable processes developed at Fraunhofer IPA enable alternative electrode materials, as well as separator and electrolyte materials, to be synthesized and evaluated in free-standing electrodes, cells, and modules. Production processes can be adapted to optimize synthesis, paste manufacturing, coating, and drying processes for new materials.

Supported by continuous tracking of material and process parameters, Fraunhofer IPA aims to accelerate the evaluation of innovative materials and the development of new manufacturing processes for next-generation battery technologies.

Services and Expertise

Fraunhofer IPA's services range from consulting through to research and development projects in the following fields:

- Planning — factory planning and energy system planning
- Production — optimization of operations ranging from small-batch production to gigafactory-scale manufacturing
- Production — manufacturing of customized sample battery cells and small series at laboratory and pilot-plant scale: half cells, button cells, pouch cells, and cylindrical cells
- Digitalization — IT architectures, modeling, and service development
- End of Life — battery disassembly and reuse
- Qualification — modular and demand-oriented advanced training services



©Fraunhofer IWS

1



©Fraunhofer IWS

2

DRYtraec Technology

In today's battery electrode production, a so-called "slurry process" is used. In this process, active materials, binders, and conductive carbon blacks are processed with water or organic solvents to form pastes (slurries). Thin metal foils are coated with these slurries. The solvent is removed from the wet layer in drying sections up to 100 meters long. This requires considerable space and energy, which is why dry coating processes are increasingly becoming the focus of cell manufacturers.

Researchers at Fraunhofer IWS addressed this issue by developing DRYtraec, an alternative production technology. In this process, a dry mixture consisting of active material, conductive carbon black, and binder is introduced into the calender gap between two counter-rotating calender rolls. The shearing force within the calender gap leads to the formation of so-called fibrils. These microscopically small, thread-like binder structures fix the active material and conductive carbon black together in a spiderweb-like structure.

Through process parameter control, a dry film is formed on the faster rotating roll. This dry film is subsequently transferred onto a current-conducting foil. At no stage in the DRYtraec process does the dry film rely solely on its own mechanical stability. Instead, the carrier roll or the current-conducting foil provides the required mechanical stabilization. According to the Fraunhofer IWS researchers, this represents a decisive advantage for achieving high process speeds and good scalability.

DRYtraec battery cathodes require less than two percent binder while exhibiting electrochemical properties equivalent to those of cathodes produced using slurry processes. To date, Fraunhofer IWS scientists have successfully produced cathodes for lithium-ion batteries (NMC and LFP), as well as for solid-state batteries (based on thiophosphate), lithium-sulfur batteries, and sodium-ion batteries. DRYtraec therefore demonstrates considerable versatility for both current and future battery production technologies.

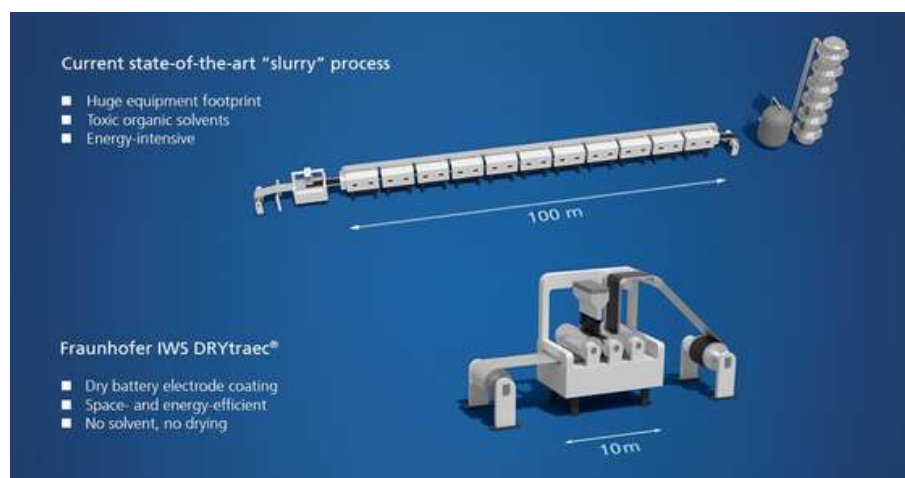

1. The prototype equipment at Fraunhofer IWS allows process development up to continuous double-sided coating.
2. Process scheme for simultaneous, double-sided coating of battery electrodes with DRYtraec.

Conventional processes for the production of battery electrodes usually work with toxic solvents and require a lot of space and energy. This is not the case with DRYtraec – a new dry coating process from Fraunhofer IWS. The technology is environmentally friendly, cost-efficient and applicable on a large scale. DRYtraec thus has the potential to revolutionize the production of battery electrodes.



© Fraunhofer IWS

1



© Fraunhofer IWS

2



© Fraunhofer IWS

3

FRAUNHOFER IWS'S OFFER

The scientists at the Fraunhofer IWS "Advanced Battery Technology Center" (ABTC) support customers across all aspects of the value chain for dry battery electrode production.

Feasibility Studies and Process Development

Fraunhofer IWS's research and development services for feasibility studies are directed equally toward material manufacturers and cell producers. In addition to evaluating novel active materials, binders, carbon blacks, and other components for their suitability for dry coating, we offer parameter studies and process development ranging from electrode sheets to roll-to-roll scale production.

Electrode Characterization

The materials science expertise of Fraunhofer IWS enables in-depth investigation of the microstructure of DRYtraec electrodes. Using scanning electron microscopy, structures can be examined across several depth layers. Additional element-specific analyses can be performed using EDX. In button cells or single-layer pouch cells, the electrochemical behavior of the electrodes can be analyzed. Further methods, including spectroscopy, X-ray diffraction, and porosimetry, enable comprehensive evaluation of DRYtraec electrodes.

Cell Structure and Evaluation

A process line for the fabrication of pouch cells at Fraunhofer IWS enables the evaluation of battery electrode performance characteristics under application-relevant conditions. This work benefits from many years of experience in the manufacturing of lithium-ion, lithium-sulfur, and solid-state battery cells. Evaluation is carried out under variable and controlled conditions, including external pressure, temperature, and performance profiles.

Technology Transfer and Licensing

Fraunhofer IWS offers system solutions up to prototype scale for R&D systems, with a focus on customized special designs. For larger-scale plants, we support specification and implementation in cooperation with plant manufacturers. Technology transfer to partners includes training and consulting programs, as well as support during acceptance and commissioning processes. Commercial utilization of the technology is enabled through licensing agreements.

1. Feasibility studies as well as process developments for dry battery electrode coating can be carried out with the system technology at Fraunhofer IWS.
2. Example of an automated stacked prototype cell at Fraunhofer IWS.
3. Fraunhofer IWS supports the development and customer installation of system technology. In this example, a prototype system for dry coating with air and moisture sensitive materials is developed.

Thin Film Technology for Energy Storage Media

METALLIZED POLYMER FILMS AS CURRENT COLLECTOR

Application

Metallized polymer films used as current collectors represent an attractive opportunity to increase both gravimetric and volumetric energy density while improving battery safety aspects and conserving scarce resources compared to conventionally used metal foils.

- Thin and lightweight current collectors for increasing volumetric and gravimetric energy density
- Replacement of metal foils with metallized polymer foils

Development Parameters

- Film thickness (base substrate) < 8 μm
- Metal thickness > 1 μm
- Total thickness < 10 μm

Technology

- Roll-to-roll process for film widths > 400 mm and strip lengths > 100 m
- Double-sided coating with Al or Cu by means of:
 - Electron beam evaporation
 - Cathode sputtering (magnetron sputtering)

Advantages

- Reduced weight and thickness
- Increased intrinsic safety of battery cells

SILICON ANODES

Application

Pure silicon anodes in lithium-ion cells have the potential to significantly increase volumetric energy density. Porous nodular structures are required to ensure high cycle stability of the cells.

- Growth of silicon in nodular structures to incorporate free volume within the layer and compensate for volume expansion.

Development Parameters

- Silicon area loading, e.g. 1–4 mgSi/cm^2 per film side (corresponding to a geometric film thickness of approximately 5–15 μm)
- Deposition rate
- Porosity

Technology

- Roll-to-roll process for film widths > 400 mm
- Coating by magnetron sputtering
- Electron beam process under development

Advantages

- High charge capacity of porous silicon layers
- Good cycle stability
- Roll-to-roll process capability

1. Metallized polymer films.
2.

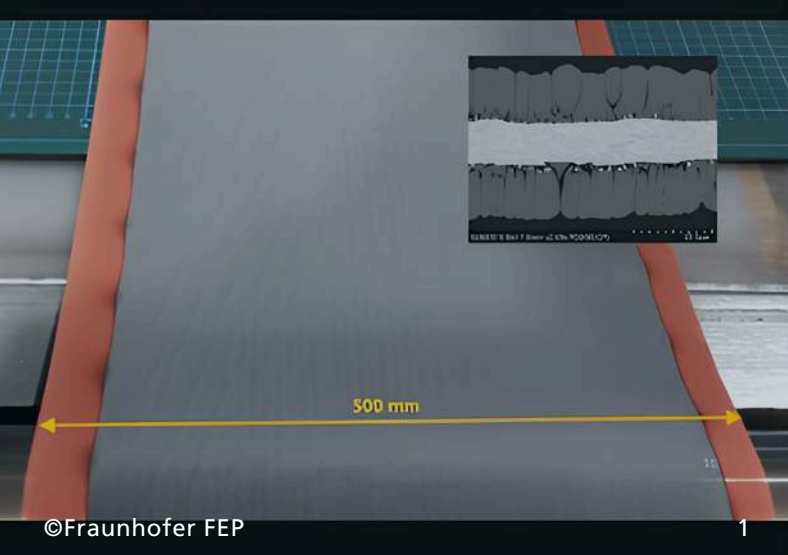

ELECTRON BEAM CO-EVAPORATION FOR POROUS LAYER STRUCTURES

Application

Porous layers with tailored properties are required, for example, in microelectronics for sensors, actuators, and other functional layers with low dielectric constants. In chemistry, porous layers are used for catalysts or filtration applications. Due to the large internal surface area of porous materials, energy conversion applications such as supercapacitors and innovative anodes for lithium-ion batteries are of particular interest. Silicon is among the promising materials for these applications. However, a porous Si matrix is required to compensate for mechanical stresses and volume expansion occurring during charging.

Development Parameters

- Materials used
- Porosity and morphology
- Technology transfer for roll-to-roll processes

Technology

- Co-evaporation of silicon and zinc
- Mixing of both elements in the vapor phase and deposition of compound layers onto metal substrates
- Subsequent annealing treatment in vacuum for zinc re-evaporation and structure formation

Advantages

- High coating rate (up to 100 nm/s demonstrated)
- Creation of a porous silicon structure that accommodates expansion during charging and minimizes capacity loss
- Process adaptability and optimization for specific battery requirements
- Long-term potential for zinc reuse within the process
- Initial charge capacity of the layers exceeding 3,000 mAh/gSi
- Comparatively good cycle stability

METALLIC LITHIUM AND PRE-LITHIATION

Motivation

Lithium layers are usually produced as thin films through rolling processes, which require the use of lubricants. By thermal vapor deposition in vacuum, lithium layers can be produced without contaminating additives at thicknesses of 1–20 μm. This enables the reproducible production of highly pure and exceptionally thin metallic lithium layers.

State of Research

- Fabrication of pure lithium thin films on metal substrates
- Optimization of layer thickness and morphology
- Development of suitable passivation layers
- Pre-lithiation of anodes

Technology

- PVD of pure metallic lithium layers through thermal evaporation at deposition rates > 100 nm/s and > 1 μm·m/min, respectively
- Deposition of Li compound layers by co-evaporation from separate crucibles for the production of pre-lithiated layers
- Deposition of protective coatings by PVD

Advantages

- High degree of freedom for optimizing anode thickness
- Highest degree of purity
- Possibility to tailor optimal layer morphology along the growth direction
- High flexibility in layer composition

1. Nodular pure silicon anode on copper foil.
2. Lithium granules as feedstock for evaporation.

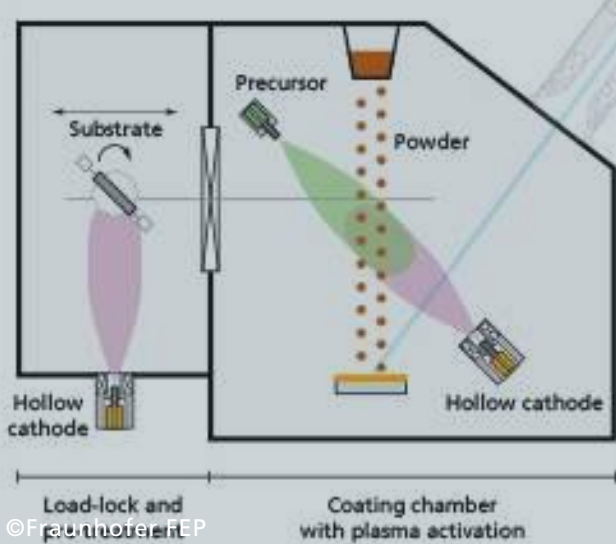

©Fraunhofer FEP

1



©Fraunhofer FEP, Jürgen Lösel

POWER-BASED Si ANODE MATERIAL AND FUNCTIONALIZATION IN arcPECVD PROCESS

Application

The use of small-scale Si particles as anode material represents an alternative approach to minimizing stresses occurring during cycling. A carbon coating on the particle surface additionally improves electronic conductivity, stabilizes the silicon, and prevents lithium and electrolyte losses caused by continued SEI formation. Fraunhofer FEP is pursuing the approach of coating Si particle surfaces with carbon using the arcPECVD process at high deposition rates.

Development Parameters

- Coating rate (≥ 35 nm/s on flat substrates already demonstrated)
- Powder delivery setup in vacuum
- Variation of coating thickness through adjustment of exposure time and particle distribution

Technology

- Precursors (e.g. C_2H_2) are converted into compact carbon coatings through exposure to an intense hollow cathode plasma
- The powder is conveyed through the plasma action zone by a specialized transport mechanism and subsequently recollected

Advantages

- Uniform all-sided coating of particles with high throughput
- High degree of flexibility regarding particle size distribution
- Flexibility in coating material through the use of different precursors

FURTHER TECHNOLOGIES

- Interfaces
- Solid-state electrolyte coatings
- Separators
- Deposition of active materials on metal foils
- Post-lithium technologies

1. NOVELLA test facility, equipped with two hollow cathode arc sources for the pre-treatment of reference substrates and for arcPECVD coating.



©K. Dobberke for Fraunhofer ISC



©Fraunhofer ISC

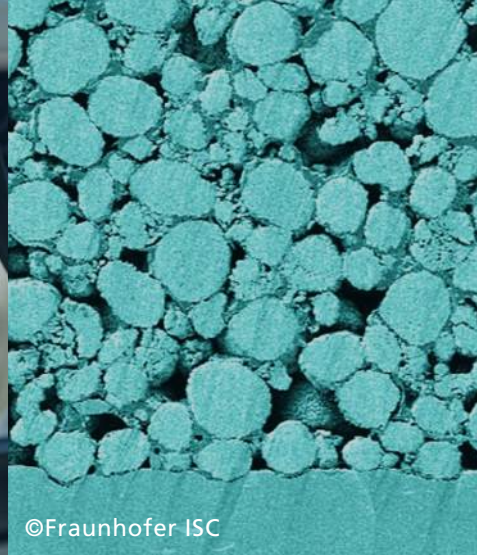

©Fraunhofer ISC

Battery Materials and Components

At the Fraunhofer Research and Development Center for Electromobility Bavaria (FZEB), the focus is on advancing the future of sustainable energy storage. FZEB specializes in the development, testing, and precise optimization of advanced battery materials and components for lithium-ion, sodium-ion, solid-state, and lead-acid batteries. Its comprehensive R&D services are tailored to a broad range of industries across the battery value chain, including suppliers of battery materials, electrode and battery manufacturers, and battery recycling companies.

Through its state-of-the-art infrastructure and interdisciplinary team of experts, FZEB develops application-oriented solutions designed to address both current and future requirements of the battery industry.

BATTERY MATERIALS AND COMPONENTS – PERFORMANCE RANGE

Evaluation of Battery Materials

- Chemical and physical evaluation of customer battery materials (e.g. ICP-OES, XRD, TG-MS, SEM/EDX, XPS, NMR, IR spectroscopy)
- Manufacturing of optimized cathodes/anodes and assembly of cells using battery materials (e.g. pouch cells, button cells, solid-state cells), including customer-supplied materials
- Electrochemical evaluation (e.g. galvanostatic cycling, impedance spectroscopy, cyclic voltammetry, dilation, plating/stripping)
- Benchmarking of customer materials against commercial state-of-the-art materials under identical test conditions

Applications: Battery materials for Li-ion, Na-ion, lead-acid, and solid-state batteries

Surface Coating and Treatment

- Development and scaling of processes for coating battery materials (e.g. by spray drying)
- Customized coating solutions (e.g. polymer coatings, inorganic coatings)
- Surface treatment of battery materials (e.g. thermal treatment, sandblasting)
- Chemical, physical, and electrochemical characterization and analysis (including customer materials)

Applications: e.g. Ni-rich NMC, Si, Li-metal, graphite, sulfide electrolytes, separators

Sodium-Ion and Lithium-Ion Batteries

- Assembly and characterization of single- and multilayer lithium- and sodium-ion prototype pouch cells (including integration of customer materials/components)
- Optimization of water- and NMP-based slurry formulations and adaptation of electrode properties (R2R processing possible for water-based electrodes)
- Investigation of the relationship between material properties and electrochemical performance

Applications: e.g. Ni-rich NMC, Si, LFP, graphite, NVP, hard carbon

Solid-State Batteries

- Development and optimization of components for solid-state batteries (e.g. cathodes, anodes, solid electrolytes)



©Fraunhofer ISC



©Fraunhofer ISC



©Fraunhofer ISC

PROCESS DEVELOPMENT – RANGE OF SERVICES

Cell Assembly

- Battery cell assembly (laboratory scale)
- Single-layer cells for material screening (e.g. coin/pouch cells, EL cells; 2–15 cm²; ~1–75 mAh)
- Multilayer cells (e.g. pouch/cylindrical cells, 15–150 cm², ~100 mAh–15 Ah)

Roll-to-Roll Coating

- Modular roll-to-roll coating line (blade/slot-die coating up to 500 mm)
- Wet-chemical deposition of electrode materials for batteries and electrochromic cells (aqueous and organic solvents)

Roll-to-Roll Lamination

- Electrode and electrolyte coating (blade/slot-die up to 300 mm) under inert atmosphere (Ar)
- Polymer electrolyte lamination and curing (IR/UV)

Solid-State Battery Cell Assembly

- Solid-state cell manufacturing
- Electrode slitting and cutting
- Automated single- and multilayer stacking and pouch-cell lamination (up to 20 cells per day, 3 × 5 cm²)

- Interface technology and surface coatings (e.g. polymer-based intermediate layers, coated active materials/solid electrolytes)
- Investigation of correlations between material properties and electrochemical performance
- Equipment for the production of solid electrolytes and components (e.g. various gloveboxes ensuring H₂O- and O₂-free conditions during all process steps, H₂S monitoring, hot press)
- Assembly, characterization, and post-mortem analysis of solid-state batteries (based on polymer and sulfide electrolytes)

Battery Recycling

- Evaluation, qualification, and testing of recycled battery materials (physical, chemical, electrochemical)
- Relithization of recycled active materials (e.g. NMC, LFP) from used batteries
- Restoration of recycled active material structures through thermal treatment (e.g. furnace with O₂, Ar, N₂, and Ar/H₂ gas atmospheres available)
- Upcycling of recycled active materials (i.e. converting old active materials into new active materials)

Lead Acid Batteries

- Testing of 12 V batteries and 2 V cells according to international standards: test capacities up to 20 V and 500 A, temperature control via water bath or climate chamber (-30°C to 85°C)
- Teardown analysis of new, cycled, and defective batteries
- Laboratory screening of battery materials: 2 V cells including paste mixing, electrode pasting, curing, and forming
- Material development for negative and positive electrodes, e.g. carbon additives for high charging capacity and low water loss
- Benchmarking of customer materials such as electrode additives, separators, or pasting paper

Applications: automotive batteries, auxiliary batteries, stationary batteries

PROCESSING OF BATTERIES

Fraunhofer Research and Development Center for Electromobility Bavaria (FZEB) has more than ten years of experience in battery processing and specializes in the development and scaling of electrode and cell manufacturing processes.

Leveraging comprehensive expertise in materials, electrode processing, electrolyte coating, and lamination, FZEB offers customized process development from laboratory to pilot scale for various battery technologies and electrochromic cells. Research activities focus on the manufacturing of single-layer and multilayer stacks at small scale for the investigation and evaluation of novel electrode materials and cell types, including lithium-ion batteries (LIB), sodium-ion batteries (SIB), solid-state batteries (SSB), and electrochromic cells.



©Fraunhofer IST, Marén Gröschel

1

Sustainable Factory Systems

Comprehensive Approach – From Process to Factory Roof

At Fraunhofer IST, the topic area of “Sustainable Factory Systems” focuses on the comprehensive design of production systems for current and future energy storage technologies. The institute’s range of services extends far beyond the planning and design of individual processes and process chains, encompassing the design of the entire factory — from individual production processes through to the factory infrastructure itself. Diverse and complex interactions between products, processes, technical building equipment, and buildings are systematically taken into account. Particular emphasis is placed on methods associated with the “digital factory,” including simulation and the development of digital twins for products and processes.

Sustainability as an Opportunity

In collaboration with its partners, Fraunhofer IST develops digital models and simulations for the planning of sustainable factory systems. The institute’s concepts support participatory factory-planning approaches that accompany the transformation toward sustainable production systems — from the initial concept through to the completed factory implementation.

Fraunhofer IST’s models create transparency regarding discrete and continuous flows of materials, energy, and substances while validating different design and operating scenarios for customer-specific factory systems. Technical interrelationships are modeled and evaluated together with their associated economic and environmental impacts. Within this context, Fraunhofer IST places particular emphasis on minimizing the environmental impact of energy storage production. The institute supports customers in the planning of large-scale battery cell factories — from the initial concept and all phases of factory planning through to implementation in industrial practice.

Another key focus area is the demand-oriented planning of decentralized renewable energy supplies for factory systems using innovative energy storage solutions based on battery and hydrogen technologies.

MATERIAL AND PROCESS DEVELOPMENT FOR NOVEL BATTERIES

Material and Process Development

Fraunhofer IST recognizes that a successful energy transition requires not only innovative materials for sustainable energy storage systems, but also suitable production processes. One of the key challenges in this context is the scaling of processes to industrial production levels.

For customers and research partners, Fraunhofer IST produces, functionalizes, and conditions novel battery materials such as solid electrolytes, active materials, and lithium-metal anodes. The institute scales associated production processes from laboratory to pilot scale and characterizes materials and intermediate products throughout the entire process chain using a broad range of analytical methods. Experimental investigations are further supported through simulation and modeling. Fraunhofer IST focuses particularly on achieving a scientific and application-oriented understanding of relevant interrelationships at both particle and cell level using advanced numerical analysis methods.

Evolution and Revolution

The production of next-generation energy storage systems requires the continuous advancement of production processes in process engineering, manufacturing technologies, and surface technologies. Together with its partners, Fraunhofer IST works on the adaptation and optimization of existing processes and facilities, while also testing and scaling innovative production technologies for future battery systems.

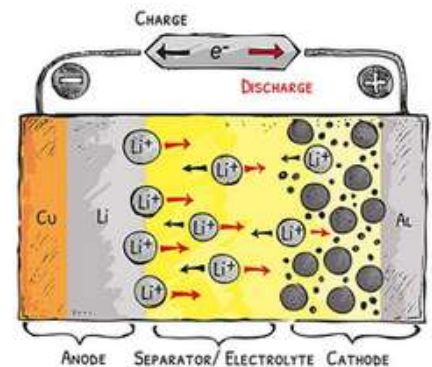

©Fraunhofer IST, Marén Gröschel

2

1. Holistic planning of battery cell production.
2. Structure and functional principle of a Li-ion solid-state battery.



©Fraunhofer IGCV | Rebekka Amann

1



©Fraunhofer IGCV | Rebekka Amann

2

Battery Technology

SMARTB4P

The first phase of the project involves a comprehensive requirements analysis and conceptual design in collaboration with all participating partners. This includes storage technology, photovoltaic forecasting, and the integration of production IT systems.

Based on this foundation, the IT networking of all relevant components and systems is implemented, and generation and consumption forecasts are developed using statistical models and machine learning approaches.

To account for the cycle-dependent aging of battery storage systems within the operating strategy, the energy storage system is modeled in detail. In addition, production-integrated storage systems are identified and mapped to enhance load-shifting potential.

Artificial intelligence methods — particularly reinforcement learning — are used to develop the actual operating strategy. This approach is intended to enable adaptive and reactive control, which will subsequently be prototypically implemented and validated at the facilities of a project partner.

BATTERIES AS A KEY TECHNOLOGY FOR A SUCCESSFUL ENERGY TRANSITION

At Fraunhofer IGCV, batteries are viewed as far more than simple energy storage devices; they are regarded as a key enabler of a climate-neutral future and an essential factor for the competitiveness of German industry in the global market. Together with its partners, Fraunhofer IGCV is actively shaping this transformation, covering topics ranging from material development and automated cell production to sustainable circular economy concepts.

A reliable power supply is fundamental to the success of the energy transition. Consequently, future battery systems must become more efficient, environmentally friendly, and sustainable. This includes increasing storage capacity without increasing battery size or weight, shortening charging times, extending service life, and continuously improving safety — for example by minimizing thermal overload risks.

To achieve these objectives, extensive research and development activities are required. Fraunhofer IGCV therefore conducts research into the manufacturing of a wide range of battery cells and energy storage systems.

Innovation Platform for Industry and SME

Battery research requires expertise from numerous scientific disciplines. While large corporations often operate dedicated research departments, small and medium-sized enterprises (SMEs) frequently have limited resources. Fraunhofer IGCV addresses this challenge by providing an innovation platform that enables regional companies to actively participate in the growing energy storage market, develop attractive business models, and contribute to Germany's energy sovereignty.

SMARTB4P | SMART BATTERY CONTROL FOR PRODUCTION

Energy Flexibility in Production Through Battery Storage

Rising electricity prices in Germany are increasingly affecting the international competitiveness of German industry. In addition to general energy costs, expenses associated with peak loads represent a significant economic burden. At the same time, companies can generate their own green electricity at considerable cost advantages through renewable energy systems such as photovoltaic installations. However, renewable power generation remains highly dependent on weather conditions.

Within this context, battery storage systems can increase on-site energy consumption and reduce costly peak loads. In industrial production environments, these storage systems must be managed as efficiently as possible while taking external factors such as weather conditions and fluctuating energy demand into account.

Smart Battery Management

The SMARTB4P research project at Fraunhofer IGCV focuses on the development of an advanced operating strategy for battery storage systems used in manufacturing companies. The strategy enables predictive control of charging and discharging processes based on situational requirements while accounting for battery aging and dynamically changing boundary conditions such as weather patterns and production capacities.

The system aims to increase on-site electricity utilization at facilities equipped with in-house renewable energy generation, avoid costly peak loads, and sustainably reduce electricity costs. To determine the most effective operating strategy despite numerous stochastic influencing factors, Fraunhofer IGCV applies methods from artificial intelligence and machine learning, particularly reinforcement learning.

1. Fraunhofer IGCV turns innovative battery concepts into real prototype cells.
2. In cell assembly, research scientists at Fraunhofer IGCV develop and analyze pouch cells as well as round and prismatic hardcase cells.



IBATECH
ITZHOE
Fraunhofer ISIT

Fraunhofer
ISIT

BATTERY CENTRES



Center for Electrical Energy Storage

FRAUNHOFER ISE'S SERVICES

- Development of new battery active materials and production processes
- Electrochemical and microstructural characterization
- Battery production technologies, including new manufacturing processes and sample battery cell production
- Development, production, and characterization of battery systems
- Battery testing and optimization, including battery safety, aging models, and battery management systems (BMS)
- Integration of battery and battery-coupled systems, including simulation, design, and evaluation
- Design and assessment of battery systems, including the impact of aging, cost developments, and regulatory frameworks on operational strategies and business models

Electrical energy storage systems are a key component of the modern energy system. The “Center for Electrical Energy Storage” at Fraunhofer ISE, with its advanced equipment and industry-oriented pilot systems, provides a unique infrastructure for a broad range of R&D services across the entire battery value chain. Through these activities, Fraunhofer ISE contributes to strengthening Germany’s competitiveness as a production location while accelerating the progress of the energy transition.

In collaboration with industrial partners, Fraunhofer ISE advances the development of sustainable, safe, and high-performance energy storage systems. By utilizing a wide range of specialized laboratory equipment, the institute’s researchers apply extensive expertise in simulation, technology assessment, and data management.

With approximately 3,700 m² of laboratory space equipped with state-of-the-art manufacturing and characterization systems for all stages of battery value creation, Fraunhofer ISE offers services through the following laboratories:

Lab Battery Materials and Cell Production

Fraunhofer ISE develops processes for industrial customers initially at laboratory scale and subsequently supports their transfer to pilot scale, including further optimization. The institute’s focus lies on sustainable processes such as dry coating technologies and the development and implementation of mini-environments aimed at reducing battery cell production costs.

Lab Characterization and Post-Mortem Analysis

Fraunhofer ISE conducts detailed material and post-mortem analyses to identify the causes of performance degradation or cell failure. These investigations contribute significantly to improving the safety and reliability of battery cells. The institute’s equipment enables testing under inert conditions, beginning with cell opening and continuing through to final analysis.

Lab Battery Engineering, Production and Testing

This laboratory focuses on the optimization of cell formation processes, customized electrical and thermal characterization, battery aging modeling, temperature management, prototype construction, second-life storage systems, innovative fast-charging technologies, destructive and non-destructive safety testing, and the development of advanced testing environments.

Lab Energy Storage Application and Innovation

Using the equipment available within its laboratories, Fraunhofer ISE simulates energy systems incorporating storage components and controls them through energy management systems. This provides industrial and research partners with an optimal environment for the development and qualification of operating and control strategies for energy storage systems.

EQUIPMENT AND SYSTEMS

Lab Battery Materials and Cell Production

- Powder synthesis, slurry production, and dry electrode manufacturing
- Roll-to-roll coating
- Semi-automatic pouch cell production
- Dry rooms with dew points of -55°C and -30°C



©Fraunhofer ISE



©Fraunhofer ISE

Lab Characterization and Post-Mortem Analysis

- Scanning electron microscopy (SEM), including EDX, EBSD, and SXES
- Crystal structure analysis (XRD)
- Chemical composition analysis (ICP-OES and elemental analysis)
- Surface characterization investigations (BET and Hg porosimetry)
- Cell opening under inert conditions in a glovebox

Lab Battery Engineering, Production and Testing

- Various electrical battery testers (5–1000 V)
- Climate chambers, including walk-in chambers
- Mechanical test rigs
- Thermal characterization of batteries using calorimetry
- Safety test benches, including propagation testing

Lab Energy Storage Application and Innovation

- Rooftop PV system with 873 kWp capacity
- Hybrid battery storage system with 836 kWh / 560 kW capacity
- Fast-charging infrastructure for electric vehicles
- Electronic loads and sinks for emulating different energy systems
- Integration of different Energy Management Systems (EMS)



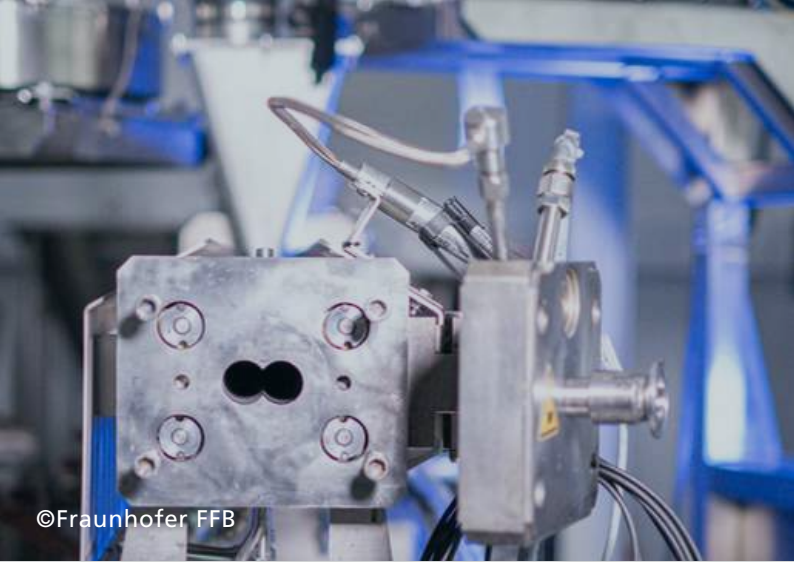

©Fraunhofer FFB



©Fraunhofer FFB

The “FFB PreFab” - Battery Production Research All Along the Line

Special Features of FFB PreFab

- Complete battery cell production for research and development
- Rentable innovation spaces in clean rooms and dry rooms for joint testing and further development of production technologies (stand-alone operation of prototypes)
- Validation and testing of prototypes for suitability on a pilot scale
- Laboratories for production-related quality assurance and research at lower TRL

Functions of the FFB PreFab

- Production for testing equipment, components, and cell designs on a pilot scale
- Research and development
- Industrial consulting and optimization of production lines and processes
- Academy and training courses

Industry-Oriented Research and Development for Battery Cell Production

Currently, more than 140 experts at BatteryCityMünster are significantly advancing the production of battery cells “Made in Germany.” The “FFB PreFab,” an open research factory, enables the fully digitized production of pouch and prismatic cells, encompassing the entire manufacturing process — from incoming goods inspection in the laboratory to the assembled battery cell. Under one roof, the technology is developed from laboratory-level maturity through the production of initial prototypes to small-batch production on a pilot line.

Small and medium-sized enterprises (SMEs), as well as large corporations, can test and scale up near-series production of new batteries and innovative plant technology at the factory. Together with experts from Fraunhofer FFB, industry challenges are analyzed in order to develop tailored solutions in close collaboration with companies. Fraunhofer FFB’s target industries include the automotive sector, energy industry, robotics, mechanical and plant engineering, chemicals, logistics, aviation, shipping, raw material recovery, and many more. The “FFB PreFab” will create an additional 20,000 square meters of production and research space. State-of-the-art equipment will enable industry-oriented production research and development in the gigawatt range.

In addition, Fraunhofer FFB is involved in national and international research projects. For this purpose, it collaborates with partners from science and industry, for example in its own innovation labs, in order to bring new battery technologies to industrial maturity and establish their production in Germany.

Battery Production Research Across the Entire Process Chain

FFB PreFab focuses on the production of pouch cells and prismatic cells for research purposes, which are used in electric cars, medical technology, smart devices, and other applications.

- All steps in battery cell production are represented here, from electrode manufacturing and cell assembly to forming.
- Complete pouch cells can be produced reproducibly in the integrated pilot line, which is a key step toward industrial scale.
- For electrode production, FFB PreFab will have a machine capacity of around 200 megawatt-hours per year.

The Innovation Labs in the “FFB PreFab”

The “FFB PreFab” is home to five innovation laboratories — four located in the south wing and one in the clean and dry room area. After commissioning, they will be used for quality assurance during production and research.

The production and laboratory areas are located close together within the “FFB PreFab”, making it easier to monitor and optimize each process step. This ensures that the quality requirements for materials and intermediate products are met step by step.

The innovation laboratories provide a foundation for studying the scaling processes involved in material synthesis and the production of solid-state batteries, along with the



©Fraunhofer FFB



©Fraunhofer FFB

solid-state electrolytes required for their operation. By collaborating with academic partners, Fraunhofer FFB combines knowledge and resources to accelerate the development of alternative battery technologies.

TESTING INNOVATIONS IN PRACTICE

Innovation Areas in Cleanrooms and Dry Rooms

Here, partners from industry and research can build, test, and further develop innovative plants and technologies. The areas function like modular “garages”: they initially enable the stand-alone operation of plant prototypes. In a further step, these can then be integrated into the pilot line for testing under realistic production conditions.

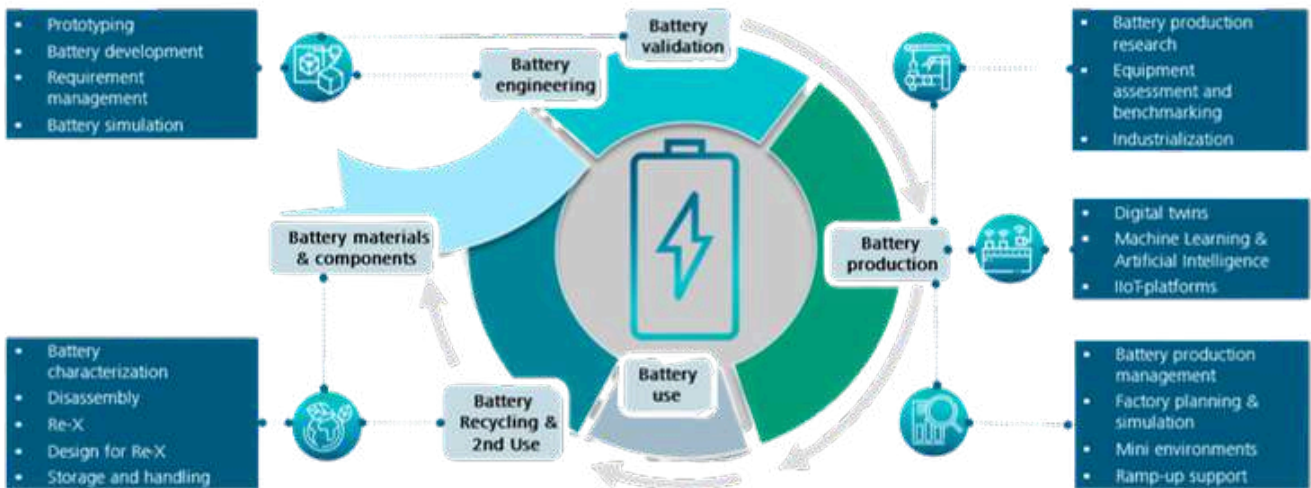

Areas of expertise of Fraunhofer Research Institution for Battery Cell Production FFB



©Fraunhofer IST, Michael Grube

1

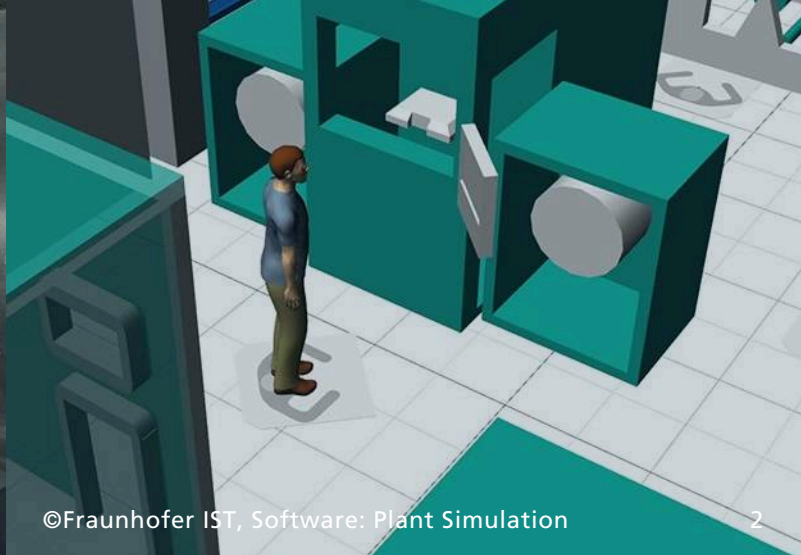

©Fraunhofer IST, Software: Plant Simulation

2

Fraunhofer Center for Energy Storage and Systems (ZESS)

FRAUNHOFER CENTER ZESS

Sectors:

- Energy
- Vehicle construction
- Digital economy / Industry 4.0

Project Partners:

- Fraunhofer Institute for Ceramic Technologies and Systems (IKTS)
- Fraunhofer Institute for Manufacturing Technology and Advanced Materials (IFAM)

Project Duration:

2018 to 2023 (launch phase)

The Fraunhofer Center for Energy Storage and Systems ZESS in Braunschweig develops innovative, sustainable, and safe battery and hydrogen technologies. Its research focuses on pioneering solid-state batteries as next-generation mobile and stationary energy storage systems, as well as innovative hydrogen technologies such as POWERPASTE. The objective is to transfer sustainable technologies from research into industrial application, thereby contributing to a more environmentally friendly future.

With state-of-the-art equipment and highly specialized laboratories, Fraunhofer ZESS provides a high-performance infrastructure for research, development, prototyping, and scaling. The new research building at Braunschweig Research Airport comprises approximately 3,400 m² of laboratory and office space, including dry rooms for cell manufacturing, energy-efficient building technology, photovoltaic systems, and a CO₂-reduced timber-steel hybrid structure with a green roof.

The center is supported by the Fraunhofer Institutes IST, IFAM, and IKTS in close cooperation with the Technical University of Braunschweig and the Battery LabFactory Braunschweig (BLB). This interdisciplinary partnership combines scientific excellence in materials science, production engineering, and system integration.

Furthermore, Fraunhofer ZESS is part of the Braunschweig LabFactories for Batteries and more (BLB+), a regional network bringing together leading research institutions in Lower Saxony to advance sustainable batteries and energy converters and actively contribute to the future of the energy and mobility transition.

Through the participation of Fraunhofer IST, IFAM, and IKTS in the Fraunhofer Battery Alliance, Fraunhofer ZESS is integrated into a nationwide network of leading battery research institutions and, together with its partners, contributes to shaping the next generation of energy storage solutions.

The center positions itself as a partner for companies, start-ups, and public-sector organizations, serving as an interface between science and industry. In collaboration with its partners, innovative technologies are developed, tested, and transformed into market-ready products for a sustainable energy future and the technological sovereignty of Germany and Europe.

Supported by the State of Lower Saxony, Fraunhofer ZESS offers a joint, high-performance research and transfer platform for the development of battery and hydrogen technologies for electromobility and stationary storage systems, both of which are key components of the energy transition. The combined expertise of Fraunhofer IST, IFAM, and IKTS, together with the Battery LabFactory Braunschweig, enables the advancement of mobile and stationary storage technologies toward market maturity and the development of prototype-ready solutions and systems.

CHALLENGE

Although Germany is one of the leading countries in energy storage research, a significant gap still exists between cutting-edge research and industrial maturity for innovative energy storage technologies. The goal of Fraunhofer ZESS is to establish a research and transfer platform that enables next-generation mobile and stationary energy storage systems to achieve market readiness.

- 1.Safe cell manufacturing at Fraunhofer ZESS technical center.
- 2.Planning support through simulation.



©Fraunhofer IFAM

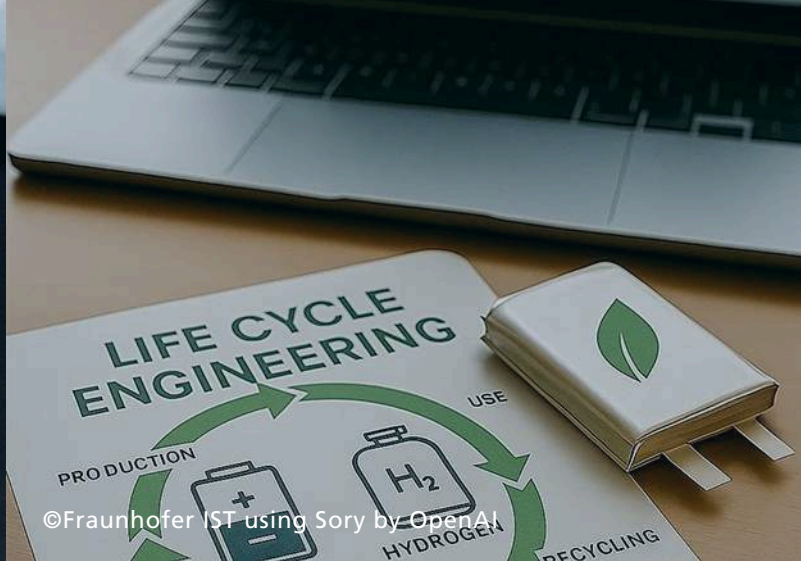

©Fraunhofer IST using Sory by OpenAI

SOLUTION

During its five-year start-up phase, Fraunhofer ZESS aims to advance next-generation mobile and stationary energy storage systems to industrial maturity. To achieve this objective, Fraunhofer ZESS promotes cooperation among various stakeholders in Lower Saxony.

Fraunhofer IST, as one of the key partners within the Fraunhofer Center, contributes by developing innovative solutions along the entire value chain. Through 21 start-up projects, research activities at Fraunhofer IST focus on:

- Material and process development
- Planning and design of processes, process chains, and factories
- Technical, economic, and ecological evaluations

ADDED VALUE

With the support of Fraunhofer IST, Fraunhofer ZESS is being established as a Fraunhofer Project Center at the Research Airport in Braunschweig. Through the synergetic collaboration of the participating partners, material systems and manufacturing processes for energy storage systems can be systematically further developed and advanced toward industrial maturity.



Advanced Battery Technology Center (ABTC)

HIGH-PERFORMANCE AND SUSTAINABLE BATTERY CELLS

The objectives of the “Advanced Battery Technology Center” (ABTC) are the development of new materials and innovative technologies for high-performance and sustainable battery cells. Expertise in battery chemistry, innovations in electrode production, and modern cell manufacturing technologies are combined through an interdisciplinary approach.

At the ABTC, researchers from Technische Universität Dresden (Chair of Inorganic Chemistry I, with a focus on materials and electrochemistry) work together under one roof with Fraunhofer IWS experts specializing in materials, surface, and laser technologies.

This interdisciplinary team develops new solutions ranging from materials and manufacturing processes to prototype cells and their evaluation. The focus is on lithium-based high-energy cells, including lithium-ion, lithium-sulfur, and solid-state batteries.

Through this approach, the ABTC addresses the complete process chain for the development of next-generation battery cells and transfers new research findings from the laboratory into application-oriented prototype systems.

CAPABILITIES

Material Evaluation

- Material analysis
- Material surface modification
- Material evaluation in prototype cells

Components and Coatings

- Electrode development
- Functional films for cell components
- High energy anodes (Li-metal and Si-anodes)

Prototype Cell Manufacturing

- Electrode cutting
- Cell assembly process
- Prototype cells

1. Li-S prototype pouch cells: New materials can be evaluated in application-oriented tests.
2. Material properties can be decisively improved by targeted coating (carbon-coated (left) and uncoated (right) battery active material).
3. Roll-to-roll slot die coating: Customer-specific solutions range from paste development to the finished electrode.
4. Automated stacking process: prototype battery cells can be set up in a controlled dry air atmosphere.

greenBatt

Kompetenzcluster
Recycling & Grüne Batterie

©Fraunhofer IST, Marén Gröschel

1

GreenBatt – Competence Cluster Recycling & Green Battery

CHALLENGE

Battery production is resource-intensive and associated with significant environmental impacts. The aim of the competence cluster is to develop innovative technologies and methods for an energy- and material-efficient battery life cycle while closing the material loop. Within the GreenBatt Cluster, Fraunhofer IST is working on promising solutions through the projects Action, EVanBatter, and S²taR.

SOLUTION

Fraunhofer IST contributes primarily through process development and evaluation methods, including Life Cycle Assessment (LCA) and Life Cycle Costing (LCC).

- In the Action project, processes and evaluation methods are being developed for the recovery and reuse of production waste generated during electrode manufacturing.
- In EVanBatter, resynthesis processes for battery materials at the end of their service life are researched and established for reuse in new batteries.
- The overall objective of the S²taR project is the investigation and evaluation of the recyclability of solid-state batteries.

ADDED VALUE

The outcomes of these research projects enable a systematic and target-oriented design of the battery life cycle while supporting the closure of material loops through improved recycling processes and the use of recycled materials.

As a result, future battery production and recycling processes can become significantly more resource-efficient and environmentally sustainable.

COMPETENCE "GREENBATT"	CLUSTER
Sectors: <ul style="list-style-type: none"> • Plant and mechanical engineering • Vehicle construction (incl. public transport with focus on automotive) • Energy 	
Project Partners: <ul style="list-style-type: none"> • Fraunhofer Institute for Ceramic Technologies and Systems IKTS • Institute of Machine Tools and Production Technology (IWF), TU Braunschweig • Institute for Particle Technology (iPAT), TU Braunschweig • Department of Process Metallurgy and Metal Recycling (IME), RWTH Aachen • Institute of Mineral and Waste Processing, Waste Disposal and Geomechanics (IFAD), TU Clausthal • Center for Solar Energy and Hydrogen Research Baden-Württemberg (ZSW) • Institute of Energy and Climate Research • Materials Synthesis and Processing (IEK-1), Forschungszentrum Jülich (FZJ) 	
Project Duration: 2021 – 2024	



1. Safe cell manufacturing at Fraunhofer ZESS technical center.
2. Planning support through simulation.
3. Overview of the projects bundled in the greenBatt cluster.



©Fraunhofer IKTS

Battery Innovation and Technology Center (BITC)

The comprehensive digitization of industrial production is a key factor in optimizing entire production chains and thereby increasing the competitiveness of companies. This is particularly relevant for growth sectors such as the large-scale production of energy storage systems and energy converters.

For this reason, the Battery Innovation and Technology Center (BITC) in Arnstadt is developing solutions for the networked and digitally supported production of energy storage systems across an area of more than 5,300 m². Researchers are testing innovative data-driven approaches for process monitoring, process control, and quality assurance on industry-scale pilot lines. Application-oriented training and continuing education programs ensure that companies along the entire value chain are integrated and qualified at an early stage.

In order to achieve the highest possible quality in battery production while minimizing waste, defects must be identified at an early stage of the manufacturing process. Using innovative non-destructive measurement and testing technologies, all relevant process parameters can be recorded at BITC.

For the resulting data volumes, AI-based concepts for intelligent aggregation, structuring, evaluation, and storage are applied. This enables the identification of error patterns, optimization of production workflows, and the establishment of holistic production data management systems. As a result, new quality criteria and standards for battery production can be established.

Within the scope of production research for energy storage systems, BITC focuses on software development through the "Data Systems" work group as well as the transfer of digital concepts into hardware components through the "Smart Machine and Production Design" activities.

In addition to application-specific battery development, Fraunhofer IKTS is also developing fundamental routines for the scalable production of complex energy storage systems and energy converters. The experience gained from battery research is currently being transferred to digitally supported production technologies for electrolyzers within the hydrogen economy as part of the hydrogen application center "Industrial Hydrogen Technologies Thuringia (WaTTh)".

SERVICES OFFERED

Production Research for Energy Storage Systems in:

- Data management
- Computing concepts
- Evaluation and analysis methods
- Workflow management
- Instrumentation and networking of process steps
- Evaluation of digitally supported production processes



©Fraunhofer ISIT

1

FAB-SH: Research Center for Applied Battery Technology

THE CHALLENGE

Energy Storage: The Key to Transforming the Global Energy Industry

Storage systems for electrical energy are essential for the transformation of the global energy industry. Their universal applicability, particularly in electromobility, makes them a central component of future-oriented energy solutions.

The current standard, the lithium-ion battery, is available in a wide range of shapes and sizes. Nevertheless, existing electrochemical storage systems are often regarded as insufficient, particularly with respect to key requirements such as energy density, low-temperature performance, and cost-effectiveness.

Innovations in Battery Technology

Researchers and companies worldwide are working to overcome these challenges. Through the optimization of existing systems and the development of new electrochemical storage materials, such as lithium-sulfur (Li/S) technologies, efforts are being made to reduce or even eliminate the current limitations of battery systems.

However, transferring these innovative storage concepts into industrial-scale production presents significant technical and economic challenges that must be addressed.

USE CASES

High-Power cell

At Fraunhofer ISIT's FAB-SH, high-performance battery cells are developed to combine high power capability, cost efficiency, and extensive customization options, making them suitable for portable devices as well as industrial applications. The underlying technologies are designed to ensure safe and reliable operation together with long service life.

Rapid Prototyping

Fraunhofer ISIT's FAB-SH rapidly develops application-specific battery cells and offers customized cell prototypes as well as small-series production in a variety of cell designs. In addition, the institute supports the transfer to industrial production through its network of qualified partners.

Dry Coating

Fraunhofer ISIT's FAB-SH develops environmentally friendly dry-coating processes for battery electrodes that enable the production of high-loading electrodes without the use of solvents. This technology contributes to increasing the energy density of lithium-ion batteries while supporting more sustainable manufacturing methods.

Smart Battery Cells

Fraunhofer ISIT's FAB-SH develops intelligent battery cells capable of monitoring electrode potentials, temperature, and pressure in real time. These integrated monitoring functions help maximize operational safety and extend the service life of battery-powered devices and systems.

OUR OFFER

Research Center for Applied Battery Technology Schleswig-Holstein (FAB-SH)

Fraunhofer ISIT's FAB-SH is your expert partner for the development of innovative energy storage solutions. Our highly flexible manufacturing technology serves as an ideal platform for the production of prototypes and small series across a broad range of application areas, including traction and stationary energy storage systems.

OUR STRENGTHS

- **Experience in Scaling:** We possess extensive expertise in the scaling of manufacturing processes and in the characterization of battery cells with a wide variety of chemistries and cell designs.
- **Customized Solutions:** Our expertise enables us to develop customized energy storage solutions precisely tailored to specific customer requirements and application scenarios.
- **Complete Systems:** In addition to cell and storage development, we also offer the development of complete systems, including the required hardware and software for efficient system control and management.

1. The new Research Center for Applied Battery Technology Schleswig-Holstein (FAB-SH) in Itzehoe.



RECENT ACTIVITIES, EVENTS CALENDAR, AND MEDIA COVERAGE



Fraunhofer Office India: Highlights of 2025

JANUARY 2025

27.01.2025 – 31.01.2025: Visit of Prof. Dr. Thilo Bein, Head of Knowledge Management, Fraunhofer LBF, to India

Prof. Dr. Thilo Bein was invited by IIT Madras to conduct workshops on batteries, charging technologies, motors, and drive systems. He also met industry partners of IIT Madras' CoZET (Centre of Zero Emission Trucking) and held discussions with Tamil Nadu Government skilling officials to explore industry-academia gaps and potential collaborations in transport, mobility training, and circular economy projects.

FEBRUARY 2025

03.02.2025 – 07.02.2025: Delegation visit from Baden-Württemberg to India

A high-level delegation led by Dr. Nicole Hoffmeister-Kraut, Minister of Economic Affairs, Labour and Housing of Baden-Württemberg, visited India to strengthen Indo-German cooperation in Circular Economy and Sustainability. The delegation included Dr. Markus Wolperdinger, Director of Fraunhofer IGB, and Dr. Hannes Spieth, Managing Director of Umwelttechnik BW. The delegation held high-level meetings in Delhi, Mumbai, and Pune, including discussions with industry leaders such as Reliance, L&T, and Aarti Industries on collaboration opportunities in circular economy. The visit was coordinated by Ms. Anandi Iyer, Director, Fraunhofer Office India.

On 05 February 2025, Fraunhofer IGB signed two strategic MoUs with IIT Ropar and BITS Pilani at the German Embassy.

- MoU between Fraunhofer IGB and IIT Ropar: The cooperation focuses on Circular Economy and Sustainability, with emphasis on the water-energy-food nexus.
- MoU between Fraunhofer IGB and BITS Pilani: The cooperation focuses on Bioeconomy, with emphasis on advancing a sustainable and climate-neutral economy through biorefinery solutions.

12.02.2025: Inaugural Women in STEM Exhibition Symposium Hosted by EXPERIMINTA

Hosted by EXPERIMINTA, the inaugural Women in STEM Exhibition Symposium celebrated the achievements of women leaders in STEM and promoted networking and knowledge exchange to inspire future generations. Ms. Anandi Iyer was recognized for her leadership and contributions to advancing gender equality and creating opportunities for women in STEM.

12.02.2025 – 14.02.2025: Fraunhofer at The Smarter E India / Intersolar India 2025

Fraunhofer Office India participated at the German Pavilion, organized by IGCC in collaboration with IGEF, showcasing Fraunhofer's expertise in Solar PV, Battery Technologies, Electric Vehicles, and Hydrogen. Mr. Sanmati Naik represented Fraunhofer at the expo and conference sessions, delivered presentations on "Novel Solar Applications – Integrated PV" and "Next-Generation Battery Innovations", and engaged with potential clients.

21.02.2025: MoU between Fraunhofer HHI and the Centre for Development of Advanced Telematics (C-DOT), Government of India

Fraunhofer HHI signed an MoU with the Centre for Development of Advanced Telematics (C-DOT), Government of India, during the visit of Dr. Neeraj Mittal, Telecom Secretary of India, to Fraunhofer HHI in Berlin. Building on earlier ministerial engagement, the partnership focuses on Quantum Communications, 5G/6G, Cybersecurity, AI, and Immersive Media, marking a key milestone in Indo-German cooperation in next-generation telecommunications technologies.

1. Prof. Thilo Bein during lab visit at IIT Madras.
2. Ms. Anandi Iyer, Dr. Andrea Gassmann, Dr. Christiane Bucher, Minister Dr. Kristina Sinemus, and Indian Consul General, Mr. Bawa S Mubarak Madras.
3. Signing of MoU. L to R: (i) Dr. Rajkumar Upadhyay, CEO, C-DOT (ii) Dr. Neeraj Mittal, Secretary, Ministry of Telecommunications (GoI) (iii) Prof. Dr. Thomas Wiegand, Executive Director, Fraunhofer HHI (iv) Dr. Michael Klee, Administration Director, Fraunhofer HHI.
4. Signing of MoU between BITS Pilani and Fraunhofer IGB.
5. Fraunhofer booth at Intersolar India 2025 showcasing its competencies.
6. Visit of the Indian Delegation to Fraunhofer HHI.
7. Signing of MoU between IIT Ropar and Fraunhofer IGB.



28.02.2025: 11th Meeting of the German Innovation Forum

The 11th German Innovation Forum, hosted by Fraunhofer Office India, brought together more than 25 leaders from leading German organizations in India to review projects on “Road Safety in India” and the “Circularity Index for the Automotive Industry.”

MARCH 2025

11.03.2025: Fraunhofer IPT – TIDCO Design Thinking Workshop

Fraunhofer IPT, as Technology Partner to Tamil Nadu Industrial Development Corporation (TIDCO), conducted a Design Thinking Workshop in Chennai to present the analysis phase outcomes for establishing an Advanced Manufacturing Innovation Cluster in Tamil Nadu. The workshop engaged policymakers, industry, startups, academia, and incubators, and laid the foundation for the design phase of the innovation and knowledge ecosystem.

20.03.2025: Indo-German Forum: Research, Innovation and Transfer – Dialogues and Networking Event

DWIH New Delhi hosted its flagship Indo-German Forum in Delhi, bringing together experts to discuss innovation and technology collaboration. Ms. Anandi Iyer participated as a speaker in the roundtable on industry cooperation and technology transfer, highlighting the role of applied research in strengthening Indo-German collaboration. The event also marked the release of the co-authored paper by Ms. Anandi Iyer, Director, Fraunhofer Office India, and Ms. Katja Lasch, Director, DWIH New Delhi, titled “Enhancing Indo-German SME Innovation & Technology Collaboration.”

28.03.2025: Science & Technology Cluster Dialogue with the Office of the Principal Scientific Adviser (O/o PSA), Government of India

Fraunhofer coordinated a virtual dialogue with the Office of the Principal Scientific Adviser (O/o PSA), Government of India, sharing expertise on Science & Technology cluster models. Fraunhofer institutes SCAI, IESE, and IGB presented solutions in healthcare, agriculture, and water management, supporting potential collaboration in key national priority areas.

APRIL 2025

10.04.2025: Meeting with Dr. Stefan Schnorr, State Secretary, German Federal Ministry for Digital and Transport

Ms. Anandi Iyer participated in a meeting with Dr. Stefan Schnorr, State Secretary at the German Federal Ministry for Digital and Transport, hosted by Dr. Philipp Ackermann, German Ambassador to India and Bhutan.

24.04.2025: Participation in the Government of Karnataka’s Sub-Committee on Centres of Excellence

Ms. Anandi Iyer was invited by the Department of Collegiate and Technical Education, Government of Karnataka, to participate in a sub-committee developing a strategic framework for Centres of Excellence in the state. The discussions focused on policy design, funding models, industry collaboration, and international partnerships to strengthen Karnataka’s higher education ecosystem.

MAY 2025

05.05.2025 – 06.05.2025: Visit of Delegation from Fraunhofer HHI and Project Planning Workshop with the Centre for Development of Telematics (C-DOT)

Following the MoU signed between Fraunhofer HHI and C-DOT in February 2025, a two-day project planning workshop was held on 05–06 May 2025 at C-DOT, New Delhi, to advance Indo-German collaboration in Quantum Communications, 5G/6G, Cybersecurity, AI, and Immersive Media.

1. Mr. Marc Schauss, Fraunhofer IPT presenting the results of the Analysis Phase
2. Ms. Anandi Iyer with Dr. Stefan Schnorr and Dr. Philipp Ackermann.
3. Project planning workshop between Fraunhofer HHI and C-DOT.
4. Dr. Ralf Schäfer with Ms. Anandi Iyer, Mr. Aditya Fuke and other senior experts from Fraunhofer HHI and FOKUS.
5. Ms. Anandi Iyer at the Department of Collegiate and Technical Education, Government of Karnataka.
6. Release of co-authored paper by Ms. Anandi Iyer, Director, Fraunhofer Office India and Ms. Katja Lasch, Director, DWIH-New Delhi.



The Fraunhofer delegation was led by Dr. Ralf Schäfer, Director, Video Division, Fraunhofer HHI, and included senior experts from Fraunhofer HHI and Fraunhofer FOKUS. The programme was coordinated by Ms. Anandi Iyer, Director, and Mr. Aditya Fuke, Senior Manager – Strategic Projects, Fraunhofer Office India.

07.05.2025: Visit of OPC Foundation Delegation to Fraunhofer Office India

Fraunhofer Office India hosted a delegation from the OPC Foundation to discuss ongoing engagements and explore potential areas of collaboration in the context of upcoming joint activities.

18.05.2025: Participation in Freiburg Energy Days and Strategic Energy Forum at Fraunhofer ISE, Freiburg

Ms. Anandi Iyer participated in an international gathering of experts from government, industry, and research to exchange views on the global energy transition. The event featured keynote addresses, expert panels, and networking with leaders shaping the future of sustainable energy. Ms. Iyer also took part in focused discussions on global energy transformation hosted at Fraunhofer ISE. The programme included keynote sessions and thematic breakout discussions with international experts exploring strategies for a secure and sustainable energy future.

20.05.2025: Board of Trustees Meeting at Fraunhofer IST, Braunschweig

Ms. Anandi Iyer participated in the Board of Trustees Meeting at Fraunhofer IST, where key developments, strategic directions, and institutional goals were reviewed in the presence of senior leadership and stakeholders. She also joined a focused workshop aimed at strengthening Indo-German cooperation in applied research, highlighting opportunities for joint innovation and knowledge exchange between institutions.

22.05.2025: Participation in AsiaBerlin Crossroads – GITEX Europe 2025

Ms. Anandi Iyer participated in AsiaBerlin Crossroads, held at CIC Berlin as part of GITEX Europe 2025. The event brought together founders, investors, and ecosystem leaders working to build cross-continental innovation bridges between Asia and Berlin. Her participation reinforced Fraunhofer's commitment to fostering international collaboration in technology and applied research.

JUNE 2025

06.06.2025: Visit of the German Federal Ministry for Research, Technology and Space (BMFTR) to Fraunhofer Office India

Ms. Kathrin Meyer, Head of Division "Cooperation with Asia and Oceania" and Co-Chair of IGSTC's Governing Board, along with Dr. Renata Feldmann from the Division for Bilateral Collaboration with the Asia and Oceania region at BMFTR, visited Fraunhofer Office India on 06 June 2025.

The visit aimed to provide comprehensive insights into Fraunhofer's initiatives in India, as well as its strategic focus on the Microelectronics and Space sectors.

09.06.2025: Kick-off Meeting with Hon'ble Minister for Higher Education, Dr. M.C. Sudhakar

Ms. Anandi Iyer was invited to participate in a high-level meeting held at Radisson Blu, Bengaluru. The session brought together the Hon'ble Minister, senior officials from the Department and Commissionerate of Higher Education, the KHET Scheme Core Team, representatives from the Asian Development Bank (ADB), and the Vision Group for Centres of Excellence (COEs) to initiate strategic discussions on advancing higher education in Karnataka.

23.06.2025: Innovate with India – Hamburg, India Week 2025

Ms. Anandi Iyer was invited to speak at the "Innovate with India" event held on 23 June 2025 in Hamburg as part of India Week 2025. She participated in the panel discussion titled "Driving Innovation through Investment and Partnership", where she shared insights on Indo-German collaboration in innovation and technology.

1. The FICCI Innovation Committee Meeting at Fraunhofer Office India.
2. Board of Trustees Meeting at Fraunhofer IST, Braunschweig.
3. Ms. Anandi Iyer at AsiaBerlin Crossroads, held at CIC Berlin as part of GITEX Europe 2025.
4. Kick-off Meeting with Hon'ble Minister for Higher Education, Govt. of Karnataka, Dr. M.C. Sudhakar.
5. Ms. Kathrin Meyer and Dr. Renata Feldmann at Fraunhofer Office India.
6. Ms. Anandi Iyer at the Freiburg Energy Days and Strategic Energy Forum at Fraunhofer ISE, Freiburg.

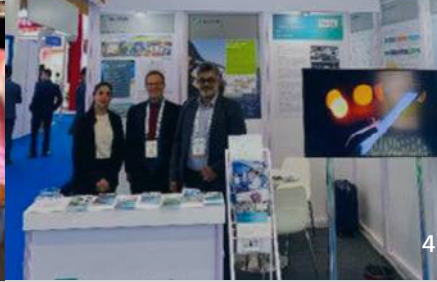

26.06.2025: Strategic Communication for Success in Indo-German Projects

Ms. Anandi Iyer participated in a panel discussion on “Strategic Communication for Success in Indo-German Projects” at the Ministry for Economy and Innovation, Hamburg. During the discussion, she shared insights on the importance of effective communication as a key enabler for successful Indo-German collaborations.

JULY 2025

08.07.2025 – 10.07.2025: Fraunhofer at the India Energy Storage Week (IESW) 2025, New Delhi

Fraunhofer participated in the 11th India Energy Storage Week (IESW) 2025, held from 08–10 July 2025 at Yashobhoomi, IICC, New Delhi, as part of the German Pavilion organized by IGCC in collaboration with IGEF. Fraunhofer showcased its competencies in battery technologies, solar photovoltaics (PV), and green hydrogen, while also contributing to the International Conference programme.

Dr. Daniel Biro, Head of Electrical Energy Storage at Fraunhofer ISE, participated in a panel discussion on battery component manufacturing and evolving production processes. He highlighted the importance of high-TRL solutions for the Indian market and emphasized the role of Fraunhofer in supporting industry through its expertise, research infrastructure, and testing facilities.

30.07.2025: Planning Workshop on Indo-German Cooperation in Electronics and Semiconductors

A planning workshop was organized at India Habitat Centre, New Delhi, jointly by Fraunhofer and EPIC Foundation India to explore opportunities for collaboration in positioning India as a global leader in electronics and semiconductors through the application of Fraunhofer’s research and innovation expertise.

This exclusive event featured sector-specific presentations from both Fraunhofer and EPIC Foundation India, highlighting India’s vast potential in the ESDM sector and presenting Fraunhofer’s vision for deepening Indo-German collaboration in this critical domain. The event then transitioned into a planning workshop involving key stakeholders from government and industry to co-develop a roadmap for bilateral cooperation.

31.07.2025: 7th Fraunhofer Innovation and Technology Platform (FIT)

Fraunhofer Office India organized the 7th Fraunhofer Innovation and Technology Platform (FIT) on 31 July 2025 at Taj Mahal Hotel, New Delhi. The event was organized with the support of the Ministry of Electronics & Information Technology (MeitY), Government of India, and focused on the transformative theme of “Microelectronics and Semiconductors.” The programme featured high-impact presentations by senior experts from Fraunhofer, showcasing a unique combination of scientific excellence, industry-driven innovation, and application-ready system solutions.

Covering the full spectrum of Fraunhofer’s technological expertise, the event addressed key focus areas including sensors, power electronics, CMOS chip design, advanced packaging, system reliability, microwave and terahertz technologies, MEMS, and skilling and workforce development.

AUGUST 2025

06.08.2025: 4th Consultative Meeting on Ease of Doing R&D, NITI Aayog

Ms. Anandi Iyer was invited as a keynote speaker at NITI Aayog’s 4th Consultative Meeting focused on improving India’s R&D ecosystem. Her expert perspectives contributed to shaping actionable policy recommendations aimed at creating a more agile, transparent, and impactful research environment across the country.

1. Group Photograph with all the speakers from Fraunhofer, EPIC Foundation India, Government, German and Indian Industry.
2. Release of a knowledge paper by Dr. Philipp Ackermann at the 7th Fraunhofer Innovation and Technology Platform.
3. Technical Session 1(L to R): Dr. Andreas Middendorf, Dr. Michael Scholles, Mr. Vinay Shenoy, Prof. Dr. Albert Heuberger, Dr. Matthias Eberlein.
4. Fraunhofer booth at the India Energy Storage Week (IESW) 2025 showcasing its competencies.
5. Ms. Anandi Iyer at the panel discussion on Strategic Communication for Success in Indo-German Projects at the Ministry for Economy and Innovation, Hamburg.



SEPTEMBER 2025

01.09.2025: Visit of Mr. M.K. Stalin, Hon'ble Chief Minister of Tamil Nadu, to Düsseldorf, Germany, to Strengthen Cooperation Between Germany and Tamil Nadu

Mr. M.K. Stalin visited Düsseldorf to strengthen cooperation between Germany and Tamil Nadu in the fields of technology, industry, and innovation. During the visit, he unveiled a Fraunhofer IPT study on the Innovation and Knowledge Ecosystem of Tamil Nadu, commissioned by TIDCO, which provided strategic inputs to strengthen the state's innovation landscape. Prof. Dr. Christian Brecher and Dr. Henning Janssen from Fraunhofer IPT attended the event.

17.09.2025 – 19.09.2025: Fraunhofer IPMS at Electronica India 2025

Fraunhofer IPMS participated in Electronica India 2025 in Bengaluru, showcasing advanced MEMS-based technologies. Dr. Michael Scholles, Corporate Business Development Manager, and Ms. Ines Schedwill from the Business Development Department represented Fraunhofer IPMS at the event. The exhibits featured advanced MEMS-based devices, including micro-displays, chemical sensors, ultrasonic transducers, optical communication modules, and spatial light modulators.

18.09.2025: Participation at the PAFI 12th Annual Forum 2025

Ms. Anandi Iyer represented Fraunhofer as a speaker at the PAFI 12th Annual Forum 2025 in New Delhi. She shared perspectives on India's global engagement and emphasized the role of innovation, research, and international collaboration in shaping the nation's future.

22.09.2025 – 23.09.2025: Cooperation with the Government of Odisha

Fraunhofer Office India held discussions with the Government of Odisha on long-term strategic cooperation aimed at building an industry-led innovation ecosystem. The discussions focused on areas including advanced materials, green energy, semiconductors, biotechnology, logistics, and skilling.

23.09.2025: Fraunhofer Battery Alliance International – General Assembly

Mr. Sanmati Naik participated in the Fraunhofer Battery Alliance International General Assembly and delivered a presentation titled "India's Battery Storage Technology Sector: Overview and Scope for Business Opportunities."

OCTOBER 2025

06.10.2025: German Indian Innovation Summit 2025, Berlin

Ms. Anandi Iyer represented Fraunhofer as a speaker at two sessions of the German Indian Innovation Summit 2025, contributing to discussions on Indo-German collaboration in research, innovation, and sustainable technologies. The summit brought together policymakers, industry leaders, and innovators from both countries to strengthen the innovation corridor between India and Germany.

07.10.2025: Gateway to India: Make in India – Partnering for Success, Munich

Ms. Anandi Iyer represented Fraunhofer at the "Gateway to India: Make in India – Partnering for Success" event in Munich, highlighting Fraunhofer's role in applied research, industrial collaboration, and sustainable innovation in strengthening Indo-German partnerships.

08.10.2025 – 09.10.2025: News9 Global Summit 2025, Stuttgart

Ms. Anandi Iyer participated as a speaker at the News9 Global Summit 2025, where she shared insights on sustainability, green technologies, and Indo-German innovation cooperation. During the event, she was also awarded the "Global Icon Award for Innovation." This recognition places her among a distinguished group of global leaders driving transformative collaboration between nations through research, innovation, and policy dialogue.

1. 5th from L: Mr. M.K. Stalin, Hon'ble Chief Minister of Tamil Nadu unveiling the study, along with team from Fraunhofer IPT.
2. Meeting with Shri. Sampad Chandra Swain, Minister for Industries, Skill Development and Technical Education, Government of Odisha.
3. Ms. Anandi Iyer at the German Indian Innovation Summit 2025.
4. Ms. Anandi Iyer at the CII Automotive Industry 4.0 Summit.
5. Meeting with Mr. Manoj Ahuja, Chief Secretary, Government of Odisha [L to R: Ms. Rashmita Panda, CEO, WSC Bhubaneswar, Mr. Bhupendra Singh Poonia, Ms. Chithra Arumugam, Mr. Manoj Ahuja, Ms. Anandi Iyer, Mr. Aditya Fuke].
6. Fraunhofer IPMS booth at Electronica India 2025 showcasing its competencies.



10.10.2025: Fraunhofer at Semiconductor Ecosystem Conference (SEC) 2025

Mr. Aditya Fuke participated as a speaker at SEC 2025, delivering a presentation on “Collaboration Opportunities between India and Germany in the Semiconductor Domain”, outlining Fraunhofer’s expertise in microelectronics and semiconductor research. He also moderated a panel discussion on “Global Partnerships for a Resilient Semiconductor Future.”

14.10.2025: Fraunhofer at the Micelio Mobility Awards 2025 and Global Clean Mobility Summit, Bengaluru

Ms. Anandi Iyer represented Fraunhofer as a panellist at the Global Clean Mobility Summit, highlighting Indo-German cooperation in clean mobility, technology transfer, and sustainable manufacturing. She also served as a jury member for the Micelio Mobility Awards, joining industry leaders in recognizing innovators and visionaries advancing emission-free transportation.

30.10.2025 – 01.11.2025: Fraunhofer at The Battery Show and Renewable Energy India Expo 2025, Greater Noida

Fraunhofer Office India coordinated the participation of Fraunhofer Institutes ISE, IWS, and IST at the 3rd edition of The Battery Show India, held alongside the 18th Renewable Energy India (REI) Expo and Energy Storage Summit (ESS) India at the India Expo Mart, Greater Noida. Fraunhofer was represented by Dr. Thomas Abendroth (IWS), Dr. Andreas Wolf (ISE), Mr. Baljeet Singh Goraya (ISE), Mr. Marcus Gapinski (IST), Mr. Cerun Alex Varkey (IST), and Mr. Sanmati Naik (Senior Manager – Energy, Fraunhofer Office India).

NOVEMBER 2025

21.11.2025: India-Germany Joint Science & Technology Committee Meeting

Ms. Anandi Iyer participated as a speaker, representing Germany, in the panel discussion on “Status and Outlook of Indo-German Cooperation in Science and Technology: Focus on Bilateral Funding Schemes and Academic Research Collaboration” at the India-Germany Joint Science & Technology Committee Meeting, organized by the Ministry of Science & Technology, Government of India, and the Federal Ministry of Research, Technology and Space (BMFTR). During the visit, she also met Dr. Silke Launert, Parliamentary State Secretary, BMFTR, to discuss opportunities for strengthening Indo-German cooperation.

26.11.2025 – 27.11.2025: Annual Network International Meeting (NetIn) – India as Country of Focus

Ms. Anandi Iyer and Mr. Saurabh Gayke participated in the International Network Meeting (NetIn) at Fraunhofer IST, focused on India and science communication for international business development. Mr. Sanmati Naik, Mr. Aditya Fuke, and Mr. Edwin Raj, participated virtually from India. They presented key activities in India, highlighting Indo-German programmes, Fraunhofer’s 17 years of engagement in India, flagship initiatives such as FIT, and current trends in production technologies.

DECEMBER 2025

02.12.2025: Release of Innovation Paper on “Indo-German SME Technology Innovation and International Cooperation”

Fraunhofer Office India and the German Centre for Research and Innovation (DWIH) New Delhi jointly released a paper on strengthening Indo-German SME technology cooperation. The publication was launched in Berlin by the Ambassador of India to Germany, with key insights presented by Ms. Anandi Iyer and Dr. Katja Lasch.

04.12.2025: Fraunhofer at the First International Conference on Science & Technology (S&T) Clusters – “Making Lives Easier through S&T”

Fraunhofer represented Germany at the First International Conference on Science & Technology Clusters, organized by the Principal Scientific Adviser to the Government of India. Dr. Fabian Hecklau participated as a speaker in the Healthcare panel, while Mr. Aditya Fuke spoke in the Smart Agriculture panel.

1. Ms. Anandi Iyer being awarded the “Global Icon Award for Innovation”.
2. Ms. Anandi Iyer at the Micelio Mobility Awards.
3. Fraunhofer booth at The Battery Show and Renewable Energy India Expo 2025, Greater Noida showcasing its competencies.
4. Release of paper on strengthening Indo-German SME technology cooperation.
5. Mr. Aditya Fuke at the Semiconductor Ecosystem Conference (SEC) 2025.
6. Ms. Anandi Iyer at the Global Clean Mobility Summit in Bangalore.
7. Ms. Anandi Iyer participating as a speaker at the News9 Global Summit 2025, Stuttgart.

EVENTS CALENDAR 2026

Date	Events	Place
09-11 Jan 2026	India visit of the H.E. Mr. Friedrich Merz, Chancellor of Federal Republic of Germany	New Delhi
19-23 Jan 2026	Visit of Ms. Hildegard Müller, President of the German Association of the Automotive Industry (VDA); Chair of Senate, Fraunhofer Gesellschaft	New Delhi, Pune, Chennai
21-25 Jan 2026	IMTEX Forming 2026	Bangalore
16-20 Feb 2026	India AI Impact Summit 2026	New Delhi
25-27 Feb 2026	The smarter E India 2026 (Intersolar + ees + Power2Drive)	Gandhinagar
18 Mar 2026	Visit of high-level German delegation, led by Senate of Berlin, to Fraunhofer Office India and Roundtable with German CEOs Forum	Bangalore
08-10 Apr 2026	Electronica India 2026 – North edition Productronica India 2026 – North edition	Greater Noida
11 May 2026	Indo-German Workshop on Rare Earth Metals	Bangalore
14 May 2026	Indo-German Roundtable on India-EU Free Trade Agreement FTA	New Delhi
08-10 July 2026	India Energy Storage Week (IESW) 2026	New Delhi
01-03 Sept 2026	PowerGen India 2025	New Delhi
16-18 Sept 2026	Electronica India 2026 – South edition Productronica India 2026 – South edition	Bangalore
17-19 Sept 2026	Semicon India 2026	New Delhi
22-24 Oct 2026	Renewable Energy India (REI) Expo 2026 The Battery Show India, ESS India	Greater Noida
Oct 2026	Windergy India 2026	Chennai
10-11 Dec 2026	PCIM India Conference 2026	
10-12 Dec 2026	ALUCAST 2026	New Delhi
04-09 Feb 2027	Bharat Mobility Global Show 2027	New Delhi

FRAUNHOFER IN INDIA: RECENT MEDIA COVERAGE



India, Germany strengthen semiconductor collaboration at 7th Fraunhofer Innovation and Technology Platform

ANI Updated At: 06:30 PM Aug 01, 2025 IST

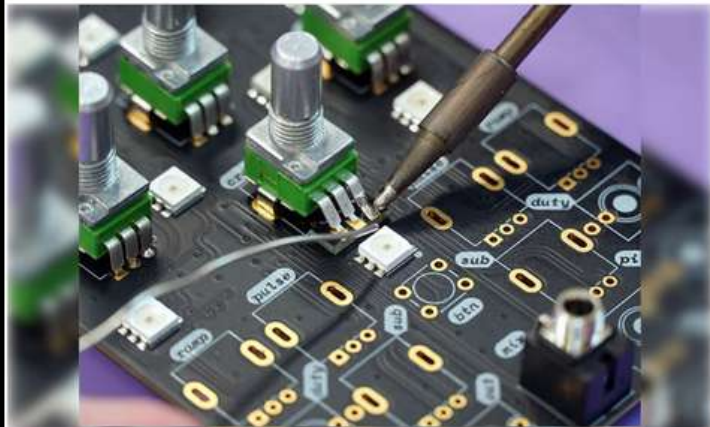

India needs to develop core electronics, become product nation

India's ecosystem is evolving right now. The Indian Government has been instrumental in bringing about a chip triangle. This is an immense opportunity for us to take this forward

Pradeep Chakraborty 30 Jul 2025 21:40 IST



Public Buses Ideal For Electrification In India: Daniel Biro (Fraunhofer)

In an interview with Saur Energy, Dr. Daniel Biro, Head of Electrical Energy Storage at Germany's Fraunhofer Institute for Solar Energy Systems (ISE) highlighted India's distinct EV growth trajectory, the promise of lithium iron phosphate (LFP) batteries, and opportunities for Indo-German cooperation on battery innovation and sustainability. Excerpts:



Public Buses Ideal For Electrification In India: Daniel Biro (Fraunhofer)



Signing of MoU between IIT Ropar and Fraunhofer IGB (Photo/Fraunhofer)

German Institute Fraunhofer signs MOUs with IIT Ropar and BITS Pilani on sustainability and circular economy

Approved semiconductor projects to produce over 24 billion chips per annum: Official

FRAUNHOFER IN INDIA: RECENT MEDIA COVERAGE

EPIC, Fraunhofer Partner To Advance India's ESDM Future

India, Germany Chart Joint Path for Semiconductor Growth at FIT 2025

At FIT 2025, India and Germany unveiled a joint knowledge paper to boost cooperation in semiconductors, focusing on design, packaging, skilling, and advanced technologies like CMOS, MEMS, and power electronics.

July 31, 2025. By E! News Network



Approved semiconductor projects to produce over 24 bn chips per annum: Official

Bridging Research and Industry: Prof. Albert Heuberger on Indo German High-Tech Partnerships

By Express Computer — On Jul 28, 2025



IMU seals new partnerships with academia & industry at IMW 2025

November 3, 2025 10:56 am Kalpana Pandey



India's approved semiconductor projects to produce over 24 billion chips annually: Official

Written By: Om Gupta

Published: August 01, 2025 12:36 IST, Updated: August 01, 2025 12:36 IST

The government has implemented a Rs 76,000-crore scheme aimed at strengthening India's semiconductor ecosystem, with a substantial portion of the funds already allocated to recently approved projects.

Telangana to integrate tech with farming

The minister also reviewed the 'Accelerating Climate-Resilient Agriculture in Telangana' project, implemented over the past two years in three villages near Vemulawada with Fraunhofer HHI's support.



Minister D Sridhar Babu at a meeting with representatives of Germany's Fraunhofer Heinrich Hertz Institute (HHI) at Secunderabad on Thursday, July 24, 2025.

"STRENGTHENING PRODUCTION WILL CUT INDIA'S GLOBAL DEPENDENCE"



Prof. Dr. Albert Heuberger
Executive Director, Fraunhofer Institute for Integrated Circuits IIS



PROF. ALBERT HEUBERGER
Fraunhofer IIS Director

New Indo-German Semiconductor Roadmap Launched, Fraunhofer IIS Director Speaks To NDTV



ANANDI IYER
FRAUNHOFER REPRESENTATIVE OFFICE

Fraunhofer Battery Alliance

Our Range of Services in Battery & Storage Tech







- Fraunhofer conducts applied research in electrochemical energy storage to develop innovative, sustainable, and high-performance battery technologies.
- Fraunhofer Battery research focuses across the entire battery value chain - from advanced materials, cell-module-system development to system integration, manufacturing processes, technology evaluation, digitalization of battery research, production, testing, lifetime and aging mechanism, battery management systems, recycling and reuse of the batteries, battery safety, and quality assurance.
- Fraunhofer has extensive experience in a wide variety of technologies from state-of-the-art (lithium-Ion, lithium-polymer...) to next-gen (lithium sulphur, metal-air, solid state...) battery technologies.
- Our research is supported by battery testing, studies, roadmaps, and techno-economic assessments, effectively bridging the gap between science and industrial application.



Fraunhofer Battery Alliance At a Glance

- 26 Fraunhofer Institutes with detailed expertise along the entire battery value chain.
- Applied research and development for state-of-the-art and emerging battery technologies.
- Your cooperation partner with comprehensive expertise and technical infrastructure.



-  Material Research
-  Cells and Cell production
-  System and Integration
-  End-of-Life and Battery Recycling
-  Simulation and Modelling
-  Testing and Evaluation

Editorial Team

Ms. Anandi Iyer
Director,
Fraunhofer Office India

Mr. Sanmati Naik,
Senior Manager - Energy (RE),
Fraunhofer Office India

405 & 406, Prestige Meridian Tower – II
30, M.G. Road, Bengaluru,
Karnataka (IND) - 560001
Tel: +91 80 4096 5008

e-mail ID: communications@fraunhofer.in | info@fraunhofer.in
Website: www.fraunhofer.in | www.fraunhofer.de